

NVE

National Vacuum Equipment
■ Part of Atlas Copco Group

4310 PRO

HEAVY DUTY VACUUM BLOWER

PRODUCT CATALOG



Challenger Series

DESIGNED, BUILT & SUPPORTED IN THE USA

800-253-5500
www.natvac.com

TABLE OF CONTENTS

- PART NUMBER REFERENCE GUIDE 3
- 4310 PRO HELICAL TRI-LOBE PRODUCT FEATURES 4
- BARE BLOWER SPECIFICATIONS 5
- 4310 PRO PACKAGES**
- OPEN PRO PAK 6
 - GEARBOX DRIVE
 - HYDRAULIC DRIVE
- PRO PAK 8
 - GEARBOX DRIVE
 - HYDRAULIC DRIVE
- SILENCER PRO PAK 10
 - GEARBOX DRIVE
 - HYDRAULIC DRIVE
- MOISTURE TRAP PRO PAK 12
 - GEARBOX DRIVE
 - HYDRAULIC DRIVE
- MAX PRO PAK 14
 - GEARBOX DRIVE
 - HYDRAULIC DRIVE
- BELT DRIVE PRO PAK 16
- TOP MOUNT PRO PAK 17
- BELLY MOUNT PRO PAK 18
- EDR/EDX - DIESEL ENGINE BELT DRIVE 19
- COMPONENTS & ACCESSORIES 20



National Vacuum Equipment
 ■ Part of Atlas Copco Group

800-253-5500 | sales@natvac.com
 2707 Aero Park Dr. | Traverse City, MI 49686

WARRANTY
REGISTRATION



PRODUCT
INFORMATION



CONDITION
OF SALES

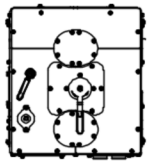
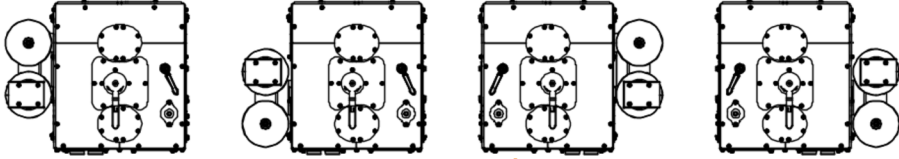
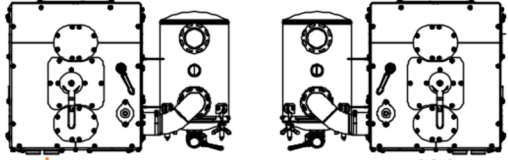
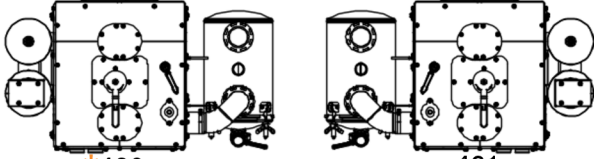

PART NUMBER REFERENCE

<p>400 SERIES PRO PAK</p>	 <p>*400 (LD LS HD HS)</p>
<p>410 SERIES SILENCER PRO PAK</p>	 <p>410 (LS/HD) 411 (LD/LS/HD/HS) *412 (LD/HS) 413 (LD/LS/HD/HS)</p>
<p>420 SERIES MOISTURE TRAP PRO PAK</p>	 <p>*420 (LD/LS/HD/HS) 421 (LD/LS/HD/HS)</p>
<p>430 SERIES MAX PRO PAK</p>	 <p>*430 (LS/HD) 431 (LD/HS)</p>

* STOCK PACKAGE CONFIGURATION

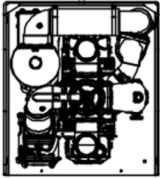

147-4310HP-300
(300 SERIES - OPEN)

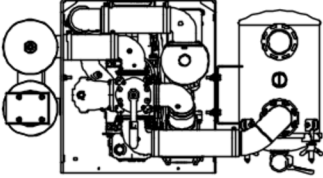

147-4310HP-330
(330 SERIES - OPEN)

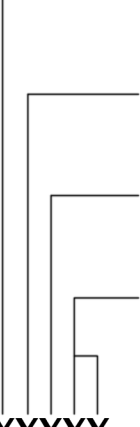

BLOWER SHAFT
L = LOW SHAFT
H = HIGH SHAFT

SHAFT ROTATION
D = CW
S = CCW

DRIVE SYSTEM
G = GEARBOX
H = HYDRAULIC

ACCESSORIES
A = ACTUATOR
V = VACUUM BREAK

147 - 4310HP - 4XX/3XX - XXXXX

(BLOWER MODEL) (COMPONENT CONFIGURATION)
(ENCLOSED 4XX/OPEN 3XX)

EXAMPLES:

- 147-4310HP-412-LDGAV (4310HP ENCLOSED, SILENCER FRAME RIGHT, LOW SHAFT, CW, GEARBOX, ACTUATOR, VAC BREAK)
- 147-4310HP-321-HSHV (4310HP OPEN, MOISTURE TRAP LEFT, HIGH SHAFT, CCW, HYDRAULIC, VAC BREAK)

4310 PRO

Helical Tri-Lobe Blower

PRODUCT FEATURES



INTERACTIVE VIDEO



FEATURES

- Continuous duty performance at maximum vacuum
- Oil-less operation
- Range of airflow - performance available to accommodate power
- Helical tri-lobe rotors engineered to increase efficiency, lower pulsations, and reduce noise
- Vacuum and pressure change over valve
- Adjustable 4" elbows with hose barbs for intake and exhaust ports
- Ballast Port manifold - cools blower through air injection
- Built-in ballast check valve
- Oil level inspection sight eyes
- Improved, longer lasting final filter
- Improved Serviceability
 - End plate design
 - Flushing ports and drain plugs
 - Carrier for sump seal



4310 PRO CHALLENGER BLOWER | SPECIFICATIONS

Air Flow - Free Air	940 CFM at 4500 RPM	
*Full Vacuum	-	
Maximum Intermittent Pressure	15 PSI	
*Operating Speed - Recommended	4000 RPM	4500 RPM
HP Required @ 27" Hg	51.4	58
HP Required @ 10 psi	39.7	44
HP Required @ 15 PSI	65.5	-
Porting Size	4"	
Shaft Size (3/8" Key)	1 1/2"	
Approximate Weight	456 lbs	

DESIGNED, BUILT & SUPPORTED IN THE USA

**The maximum allowable operating vacuum will vary depending on R.P.M., ambient temperature, altitude and time running. The basic principle to keep in mind is - faster R.P.M., higher air temperature and longer run time all equal more heat in blower. When installing a 4310 PRO blower we recommend a normal R.P.M. of 4000. Other speeds are OK as long as exhaust gas temperatures read on the supplied thermometer do not exceed 380 degrees F. Maximum of 4500 R.P.M is for intermittent use only. Weights & Measurements are for reference only. Prices subject to change at any time.*

4310 PRO BARE BLOWER

DESIGNED, BUILT & SUPPORTED IN THE USA

Challenger Series

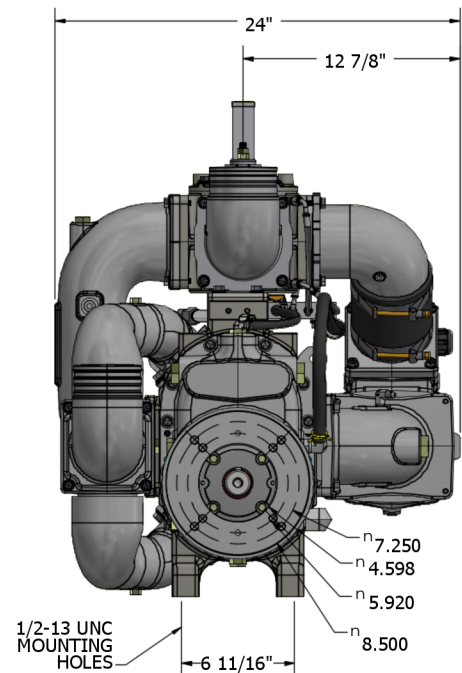
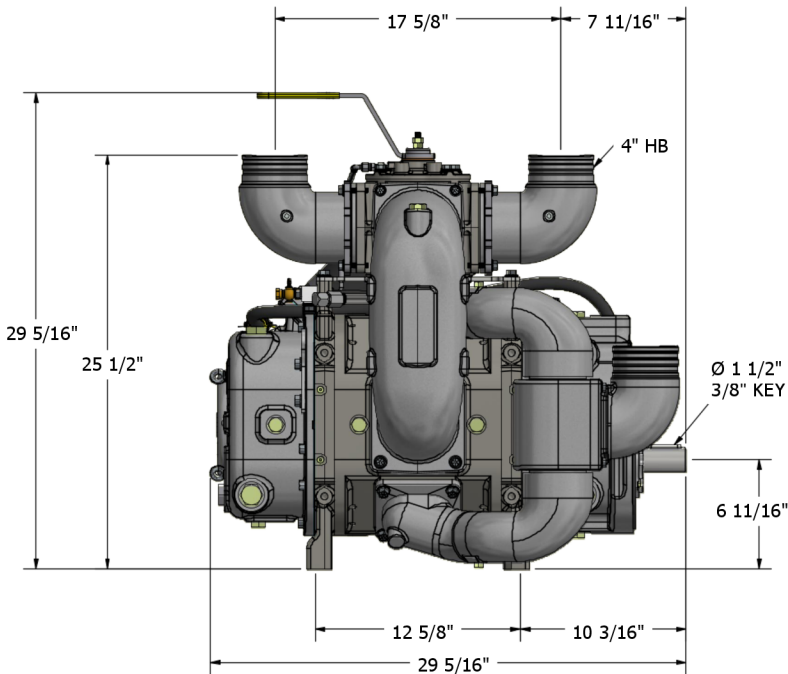
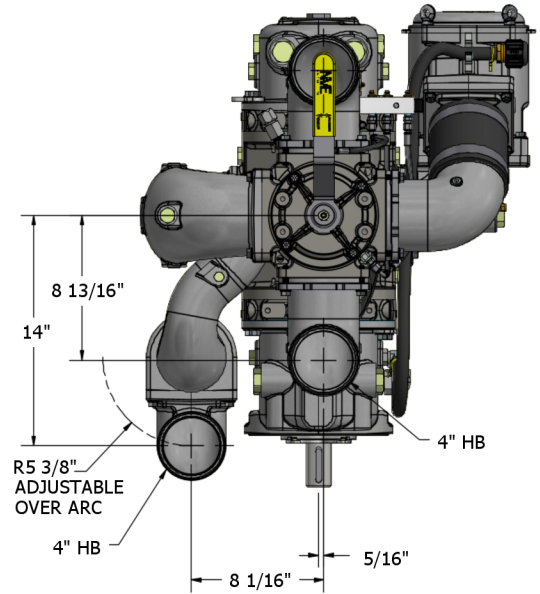
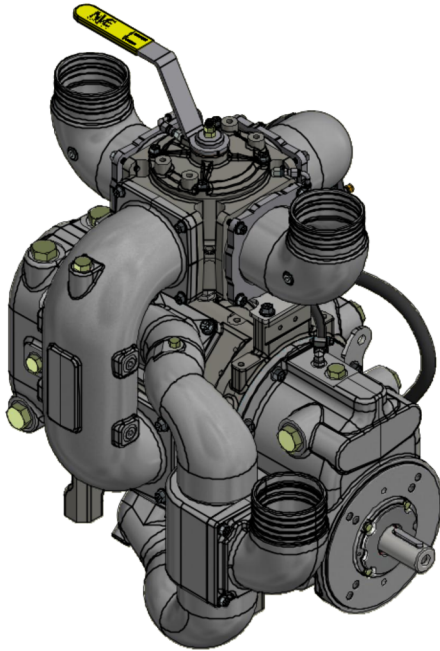

PRODUCT DESCRIPTION | 4310 PRO BARE BLOWER

PART NUMBER

WEIGHT

CHALLENGER 4310 PRO BLOWER AND BALLAST - CW

131-4310HP-LDB

375 LBS

CHALLENGER 4310 PRO BLOWER AND BALLAST - CCW

131-4310HP-LSB

375 LBS

CHALLENGER 4310 PRO BLOWER WITH MANIFOLD AND BALLAST - CW (PICTURED)

131-4310HP-LDM

450 LBS

CHALLENGER 4310 PRO BLOWER WITH MANIFOLD AND BALLAST - CCW

131-4310HP-LSM

450 LBS

*The maximum allowable operating vacuum will vary depending on R.P.M., ambient temperature, altitude and time running. The basic principle to keep in mind is - faster R.P.M., higher air temperature and longer run time all equal more heat in blower. When installing a 4310 PRO blower we recommend a normal R.P.M. of 4000. Other speeds are OK as long as exhaust gas temperatures read on the supplied thermometer do not exceed 380 degrees F. Maximum of 4500 R.P.M is for intermittent use only. Weights & Measurements are for reference only. Prices subject to change at any time.

4310 PRO PACKAGES

OPEN PRO PAK | GEARBOX DRIVE

DESIGNED, BUILT & SUPPORTED IN THE USA

Challenger Series

Features

- Frame Mount
- 500 series 1:2 ratio gearbox
- Optional: Silencers (pictured) and/or Moisture Trap
- 3/8" powder coat painted frame
- Easily accessible service points
- Blower flush kit
- Enhanced ballast and exhaust silencing for quieter operation
- Ballast check valve for pressure operation
- L 44 9/16" W 38 15/16" H 29 11/16"



*ALSO AVAILABLE IN
MAX PRO PAK

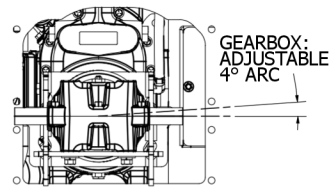
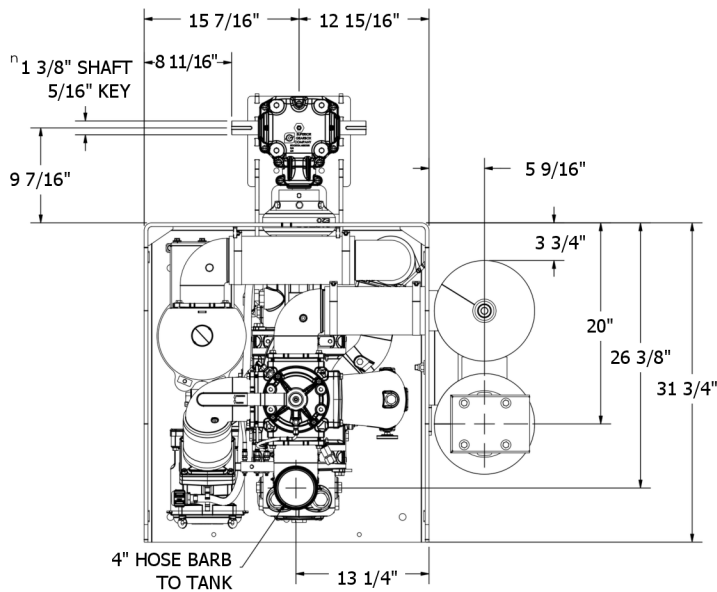

BLOWER IS
AVAILABLE WITH
PNEUMATIC
ACTUATOR

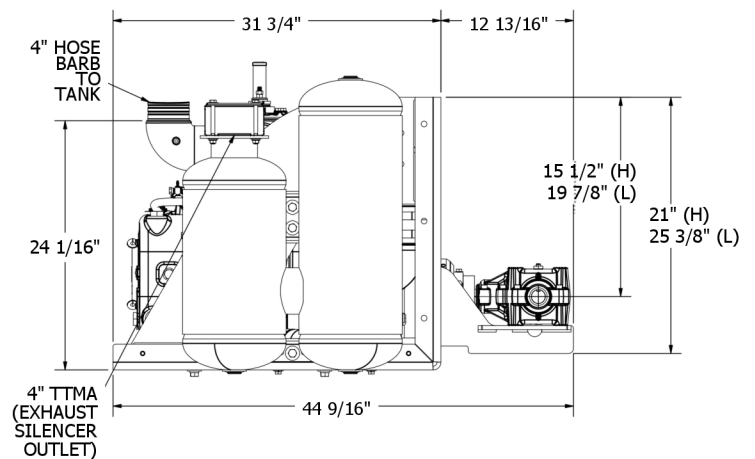
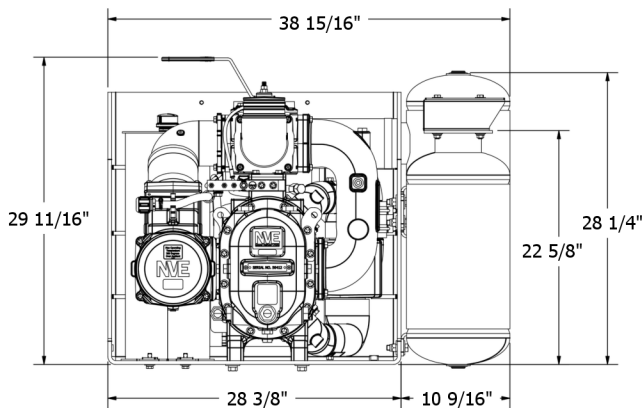

(H) HIGH SHAFT GEARBOX / (L) LOW SHAFT GEARBOX

PRODUCT DESCRIPTION

4310 PRO FRAME MOUNT, LOW SHAFT, GEARBOX DR, OPEN, SILENCER FRAME RIGHT

PART NUMBER

147-4310HP-312-LDG

WEIGHT

945 LBS

4310 PRO PACKAGES

OPEN PRO PAK | HYDRAULIC ADAPTER

DESIGNED, BUILT & SUPPORTED IN THE USA

Challenger Series

Features

- Frame Mount
- SAE C face hydraulic adapter
- Hydraulic motor not included
- Optional: Silencers (pictured) and Moisture Trap
- 3/8" powder coat painted frame
- Easily accessible service points
- Enhanced ballast and exhaust silencing for quieter operation
- Ballast check valve for pressure operation
- Blower flush kit
- L 34 9/16" W 38 15/16" H 29 3/4"

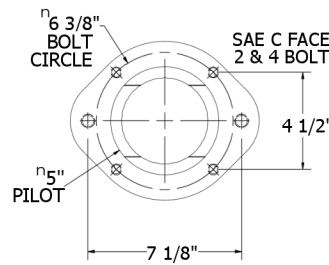
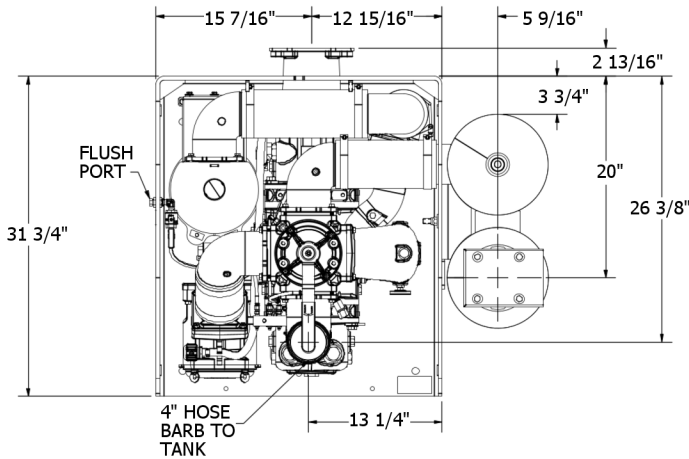

*ALSO AVAILABLE IN MAX PRO PAK

BLOWER IS AVAILABLE WITH PNEUMATIC ACTUATOR

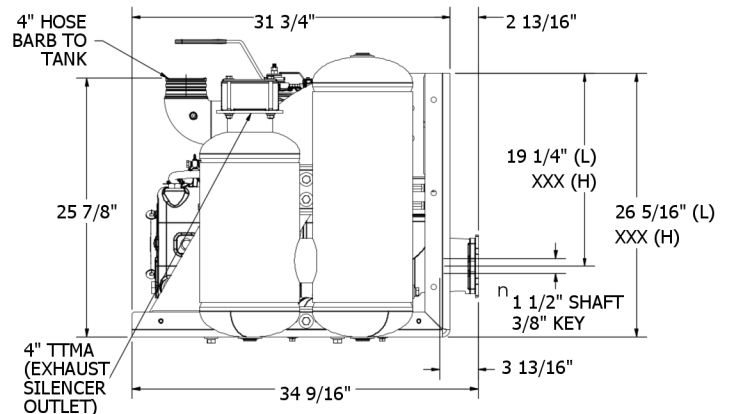
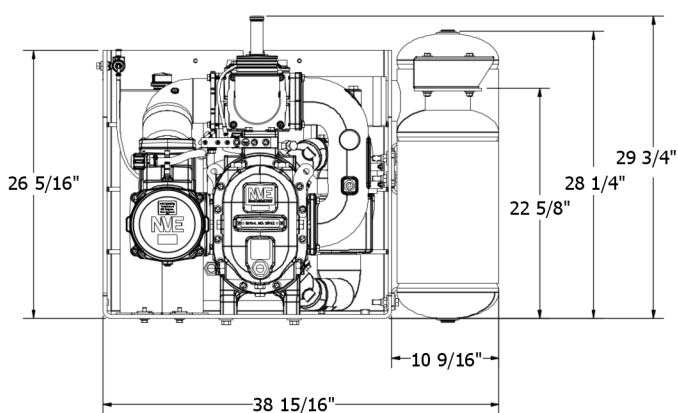

PRODUCT DESCRIPTION

4310 PRO FRAME MOUNT, LOW SHAFT, HYD DR, OPEN, SILENCER FRAME RIGHT

PART NUMBER

147-4310HP-312-LDH

WEIGHT

900 LBS

4310 PRO PACKAGES

PRO PAK | GEARBOX DRIVE

DESIGNED, BUILT & SUPPORTED IN THE USA

Challenger Series

Features

- Frame Mount
- 500 series 1:2 ratio gearbox
- Improved mounting accessibility
- 3/8" powder coat painted frame
- Stainless steel cabinet with larger door
- Easily accessible service points
- Enhanced ballast silencing for quieter operation
- Ballast check valve for pressure operation
- Blower flush kit
- L 45 5/8" W 28 1/2" H 29 3/4"

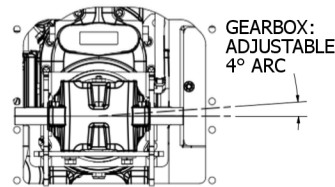
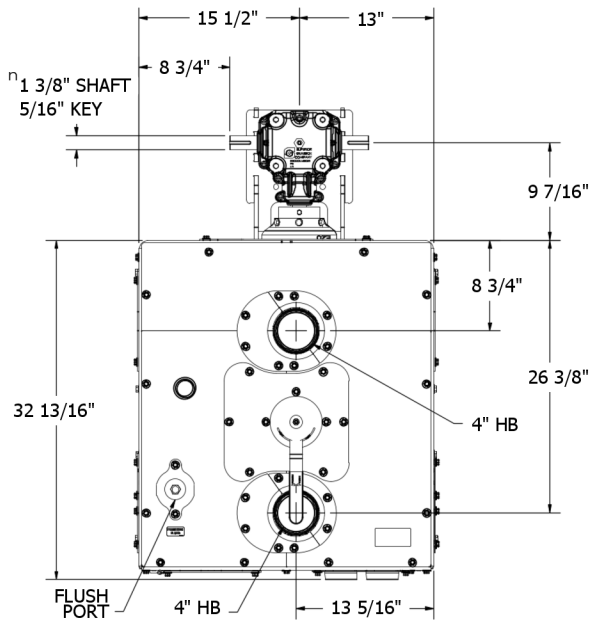

BLOWER IS AVAILABLE WITH PNEUMATIC ACTUATOR

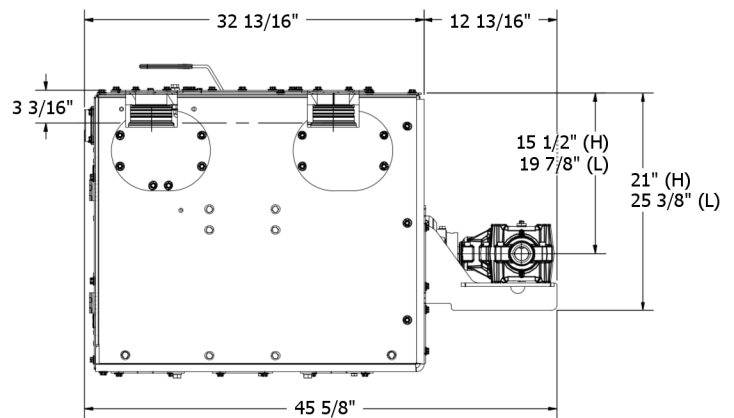
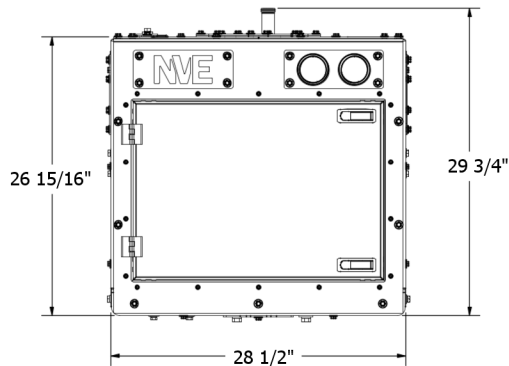

(H) HIGH SHAFT GEARBOX / (L) LOW SHAFT GEARBOX

DESCRIPTION	PART NUMBER	WEIGHT
4310 PRO FRAME MOUNT, HIGH SHAFT, GEARBOX DR, ENCLOSED (PICTURED)	147-4310HP-400-HSG	960 LBS
4310 PRO FRAME MOUNT, HIGH SHAFT, GEARBOX DR, ENCLOSED, W/ ACTUATOR	147-4310HP-400-HSGA	990 LBS
4310 PRO FRAME MOUNT, LOW SHAFT, GEARBOX DR, ENCLOSED	147-4310HP-400-LDG	960 LBS
4310 PRO FRAME MOUNT, LOW SHAFT, GEARBOX DR, ENCLOSED, W/ ACTUATOR	147-4310HP-400-LDGA	990 LBS
4310 PRO FRAME MOUNT, LOW SHAFT, GEARBOX DR, ENCLOSED, VAC	147-4310HP-400-LDGV	960 LBS
4310 PRO FRAME MOUNT, HIGH SHAFT, GEARBOX DR, ENCL, VAC	147-4310HP-400-HSGV	960 LBS

4310 PRO PACKAGES

PRO PAK | HYDRAULIC ADAPTER

DESIGNED, BUILT & SUPPORTED IN THE USA

Challenger Series

Features

- Frame Mount
- SAE C face hydraulic adapter
- Hydraulic motor not included
- Improved mounting accessibility
- 3/8" powder coat painted frame
- Stainless steel cabinet with larger door
- Easily accessible service points
- Enhanced ballast silencing for quieter operation
- Ballast check valve for pressure operation
- Blower flush kit
- L 35 5/8" W 28 1/2" H 29 3/4"

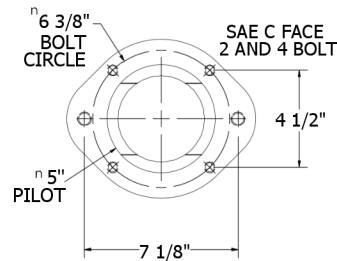
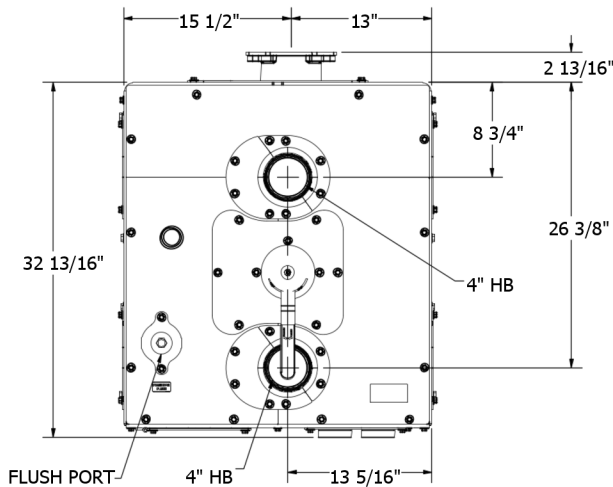

BLOWER IS AVAILABLE WITH PNEUMATIC ACTUATOR

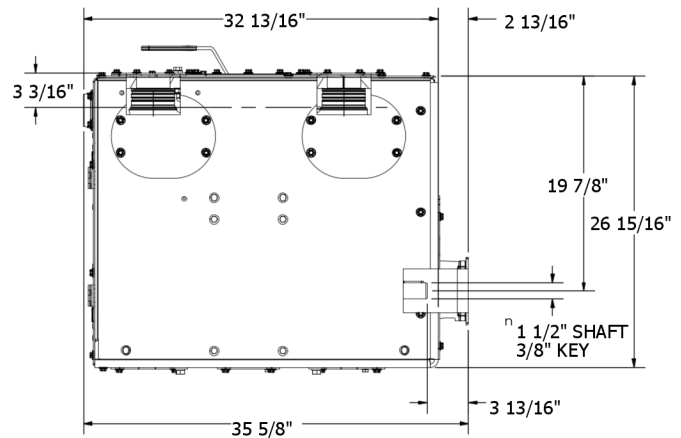
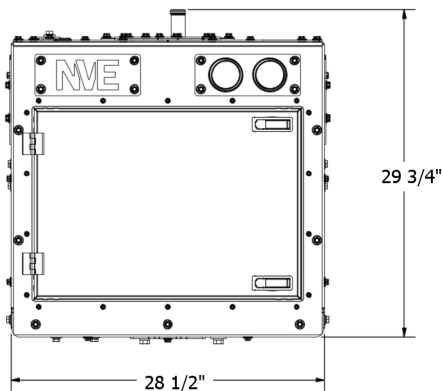

DESCRIPTION

4310 PRO FRAME MOUNT, LOW SHAFT, HYD DR, ENCLOSED (PICTURED)

4310 PRO FRAME MOUNT, LOW SHAFT, HYD DR, ENCLOSED, W/ ACTUATOR

PART NUMBER

147-4310HP-400-LDH

147-4310HP-400-LDHA

WEIGHT

915 LBS

950 LBS

4310 PRO PACKAGES

SILENCER PRO PAK | GEARBOX DRIVE

DESIGNED, BUILT & SUPPORTED IN THE USA

Challenger Series

Features

- Frame Mount
- 500 series 1:2 ratio gearbox
- Improved mounting accessibility
- 3/8" powder coat painted frame
- Stainless steel cabinet with larger door
- Easily accessible service points
- Enhanced ballast and exhaust silencing for quieter operation
- Ballast check valve for pressure operation
- Blower flush kit
- L 45 5/8" W 39 1/2" H 29 11/16"

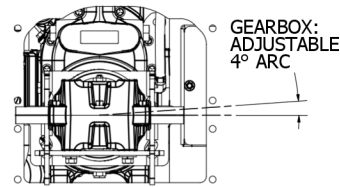
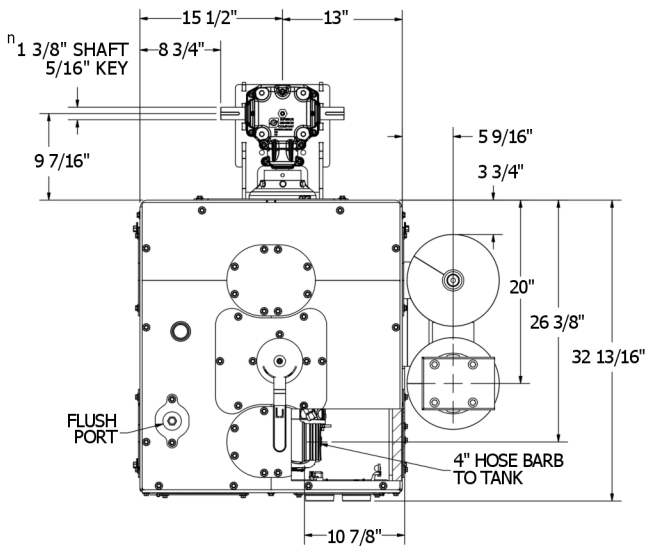

BLOWER IS AVAILABLE WITH PNEUMATIC ACTUATOR

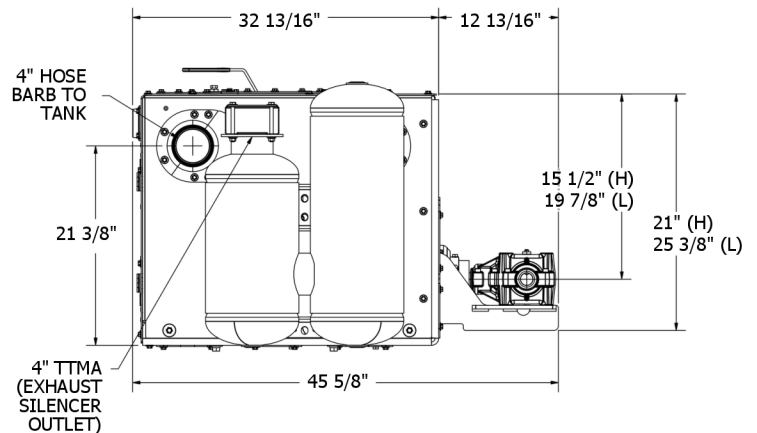
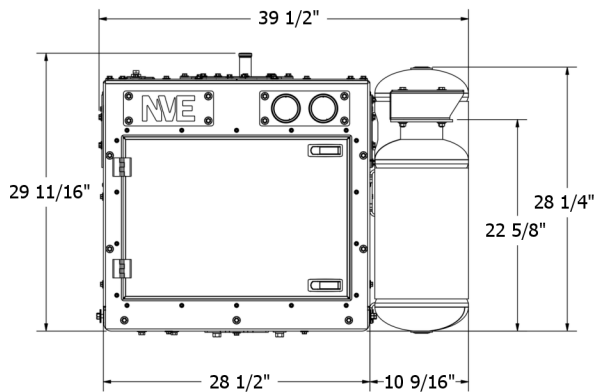

(H) HIGH SHAFT GEARBOX / (L) LOW SHAFT GEARBOX

PRODUCT DESCRIPTION	PART NUMBER	WEIGHT
4310 PRO FRAME MOUNT, HIGH SHAFT, GEARBOX DR, ENCL, SILENCER FRAME LEFT	147-4310HP-410-HDG	1070 LBS
4310 PRO FRAME MOUNT, HIGH SHAFT, GEARBOX DR, ENCL, SILENCER FRAME LEFT, W/ ACUATOR	147-4310HP-410-HDGA	1100 LBS
4310 PRO FRAME MOUNT, LOW SHAFT, GEARBOX DR, ENCL, SILENCER FRAME LEFT	147-4310HP-410-LSG	1070 LBS
4310 PRO FRAME MOUNT, LOW SHAFT, GEARBOX DR, ENCL, SILENCER FRAME LEFT, W/ ACTUATOR	147-4310HP-410-LSGA	1100 LBS
4310 PRO FRAME MOUNT, HIGH SHAFT, GEARBOX DR, ENCL, SILENCER FRAME RIGHT	147-4310HP-412-HSG	1070 LBS
4310 PRO FRAME MOUNT, HIGH SHAFT, GEARBOX DR, ENCL, SILENCER FRAME RIGHT, W/ ACTUATOR	147-4310HP-412-HSGA	1100 LBS
4310 PRO FRAME MOUNT, LOW SHAFT, GEARBOX DR, ENCL, SILENCER FRAME RIGHT (PICTURED)	147-4310HP-412-LDG	1070 LBS
4310 PRO FRAME MOUNT, LOW SHAFT, GEARBOX DR, ENCL, SILENCER FRAME RIGHT, W/ ACTUATOR	147-4310HP-412-LDGA	1100 LBS

4310 PRO PACKAGES

SILENCER PRO PAK | HYDRAULIC ADAPTER

DESIGNED, BUILT & SUPPORTED IN THE USA

Challenger Series

Features

- Frame Mount
- SAE C face hydraulic adapter
- Hydraulic motor not included
- Improved mounting accessibility
- 3/8" powder coat painted frame
- Stainless steel cabinet with larger door
- Easily accessible service points
- Enhanced ballast and exhaust silencing for quieter operation
- Ballast check valve for pressure operation
- Blower flush kit
- L 35 5/8" W 39 7/16" H 29 3/4"

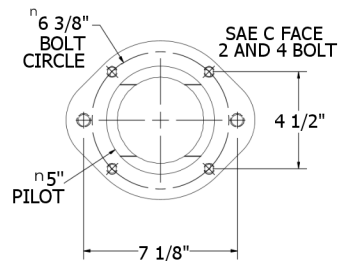
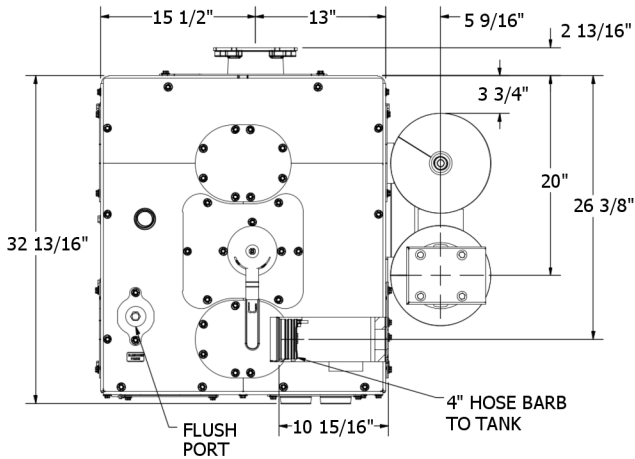

BLOWER IS AVAILABLE WITH PNEUMATIC ACTUATOR

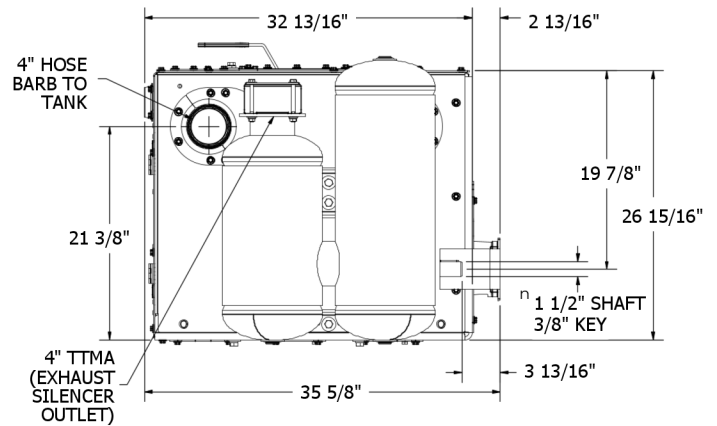
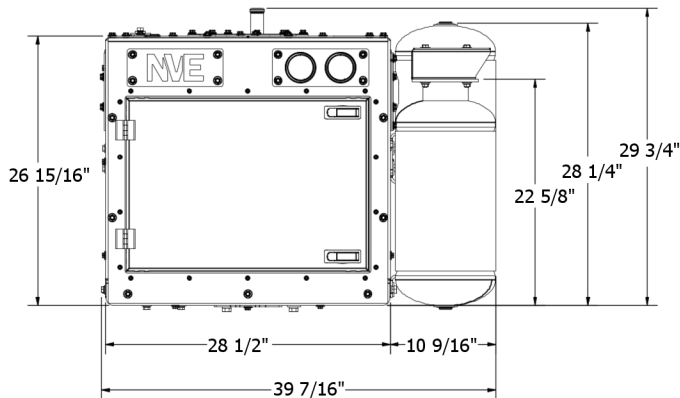

PRODUCT DESCRIPTION

4310 PRO FRAME MOUNT, LOW SHAFT, HYD DR, ENCL, SILENCER FRAME RIGHT (PICTURED)

4310 PRO FRAME MOUNT, LOW SHAFT, HYD DR, ENCL, SILENCER FRAME RIGHT, W/ ACTUATOR

PART NUMBER

147-4310HP-412-LDH

147-4310HP-412-LDHA

WEIGHT

1025 LBS

1050 LBS

Features

- Frame Mount with Horizontal Moisture Trap
- 500 series 1:2 ratio gearbox
- Improved mounting accessibility
- 3/8" powder coat painted frame
- Stainless steel cabinet with larger door
- Easily accessible service points
- Enhanced Ballast silencing for quieter operation
- Ballast check valve for pressure operation
- Blower flush kit
- **L 45 5/8" W 48 5/16" H 29 11/16"**

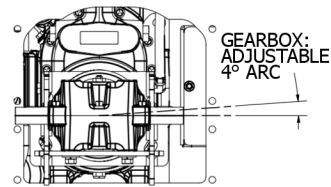
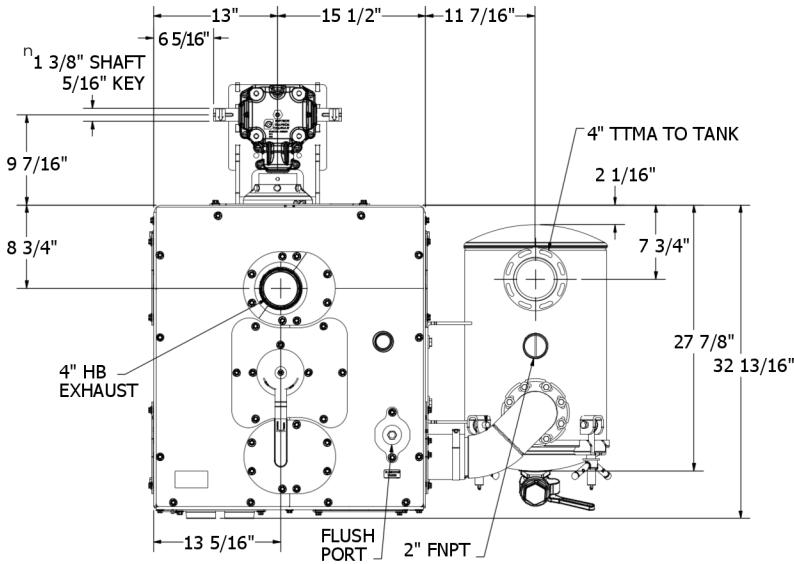

BLOWER IS AVAILABLE WITH PNEUMATIC ACTUATOR

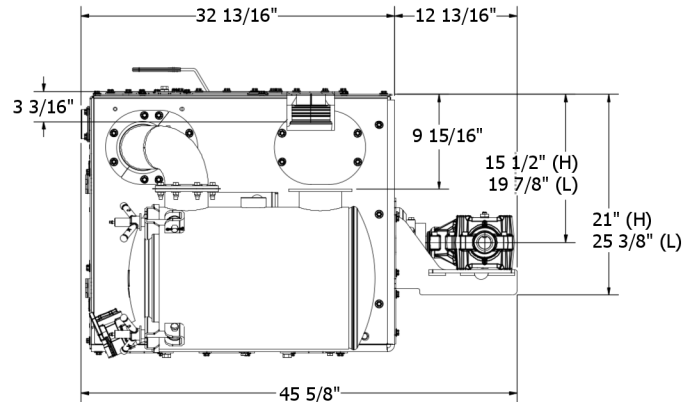
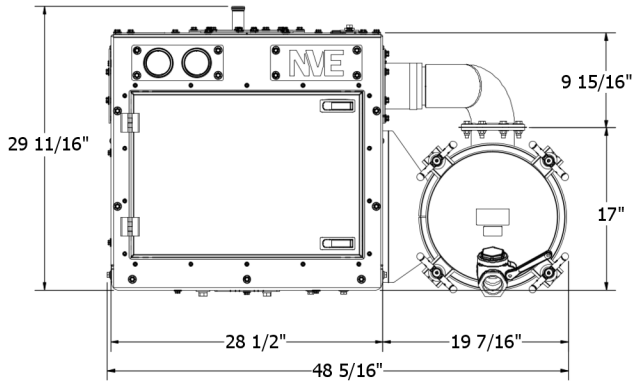

(H) HIGH SHAFT GEARBOX / (L) LOW SHAFT GEARBOX

PRODUCT DESCRIPTION	PART NUMBER	WEIGHT
4310 PRO FRAME MOUNT, HIGH SHAFT, GEARBOX DR, ENCL, TRAP RIGHT	147-4310HP-420-HDG	1120 LBS
4310 PRO FRAME MOUNT, LOW SHAFT, GEARBOX DR, ENCL, TRAP RIGHT (PICTURED)	147-4310HP-420-LSG	1120 LBS
4310 PRO FRAME MOUNT, LOW SHAFT, GEARBOX DR, ENCL, TRAP RIGHT, W/ ACTUATOR	147-4310HP-420-LSGA	1150 LBS
4310 PRO FRAME MOUNT, LOW SHAFT, GEARBOX DR, ENCL, TRAP LEFT	147-4310HP-421-LDG	1120 LBS
4310 PRO FRAME MOUNT, LOW SHAFT, GEARBOX DR, ENCL, TRAP LEFT, W/ ACTUATOR	147-4310HP-421-LDGA	1150 LBS

Features

- Frame Mount with Horizontal Moisture Trap
- SAE C face hydraulic adapter
- Hydraulic motor not included
- Improved mounting accessibility
- 3/8" powder coat painted frame
- Stainless steel cabinet with larger door
- Easily accessible service points
- Ballast check valve for pressure operation
- Enhanced Ballast Silencing for quieter operation
- Blower flush kit
- L 35 5/8" W 48 5/16" H 29 3/4"

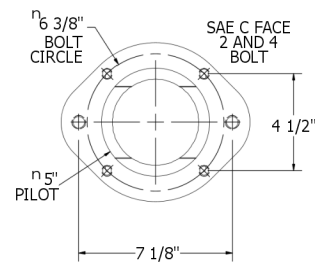
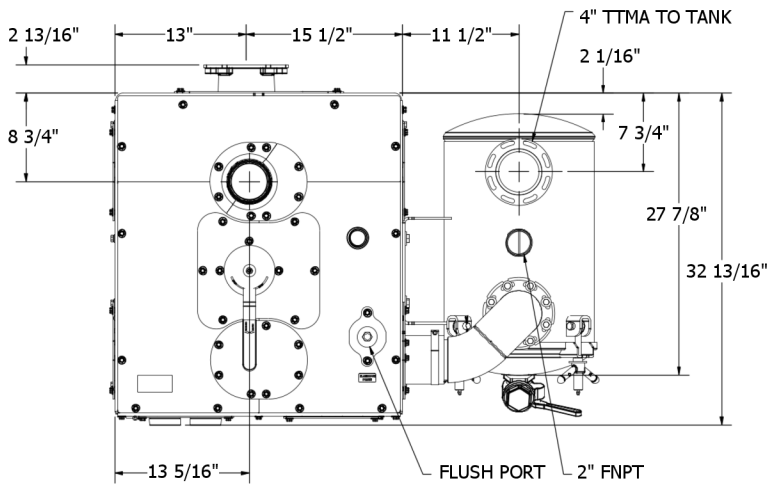
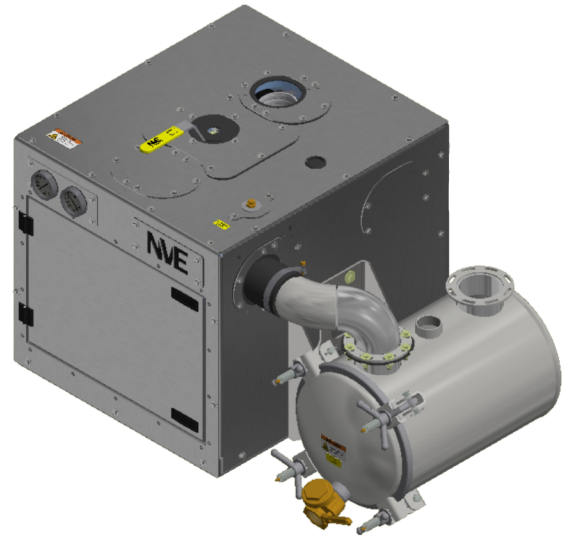

BLOWER IS AVAILABLE WITH PNEUMATIC ACTUATOR

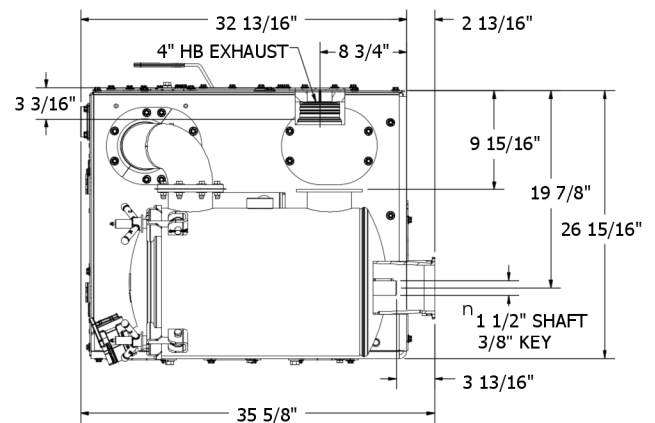
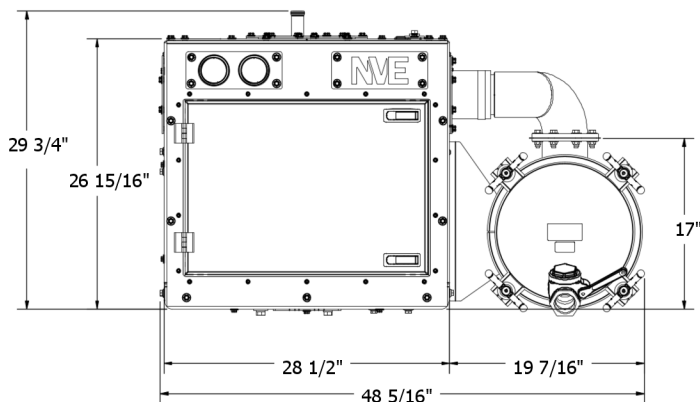

PRODUCT DESCRIPTION

4310 PRO FRAME MOUNT, LOW SHAFT, GEARBOX DR, ENCL, TRAP RIGHT

4310 PRO FRAME MOUNT, LOW SHAFT, GEARBOX DR, ENCL, TRAP RIGHT W/ ACTUATOR

PART NUMBER

147-4310HP-420-LSH

147-4310HP-420-LSHA

WEIGHT

1070 LBS

1100 LBS

4310 PRO PACKAGES

MAX PRO PAK | GEARBOX DRIVE

DESIGNED, BUILT & SUPPORTED IN THE USA

Challenger Series

Features

- Frame Mount with Silencers & Horizontal Moisture Trap
- 500 Series 1:2 ratio gearbox
- Improved mounting accessibility
- 3/8" powder coat painted frame
- Stainless steel cabinet with larger door
- Easily accessible service points
- Enhanced ballast and exhaust silencing for quieter operation
- Ballast check valve for pressure operation
- Blower flush kit
- L 45 5/8" W 58 1/2" H 29 11/16"

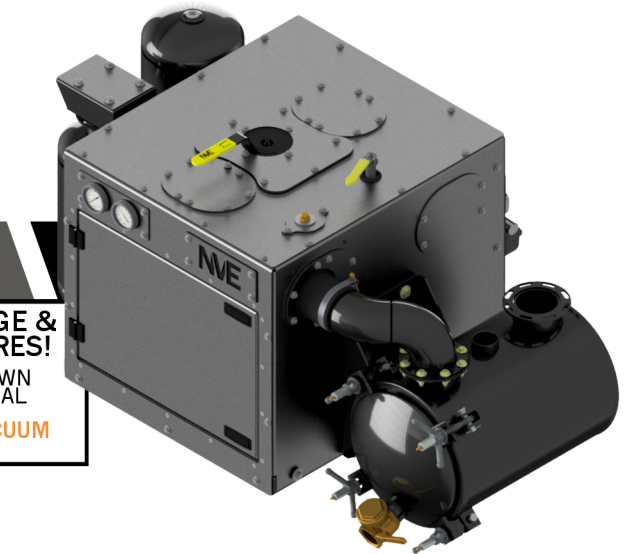
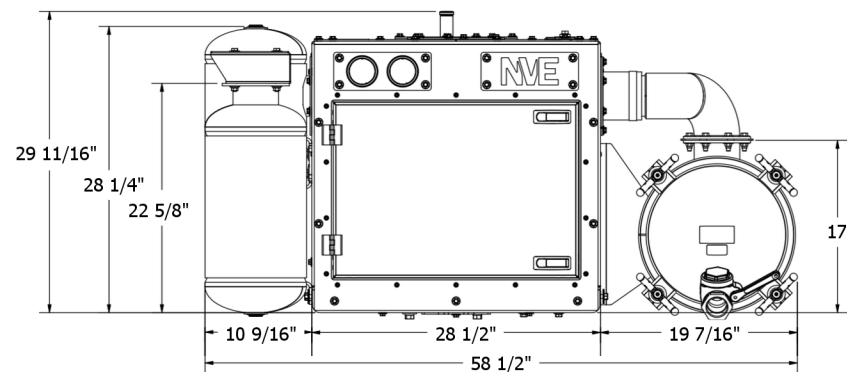
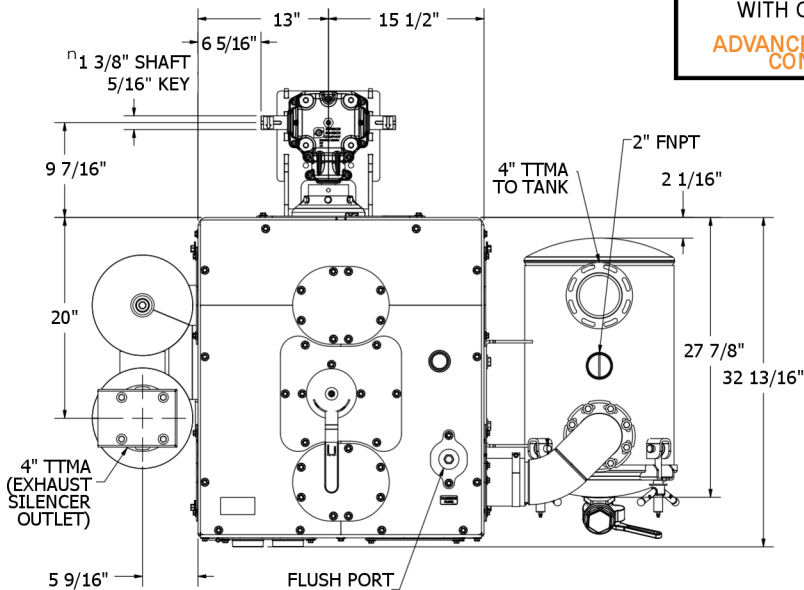

*ALSO AVAILABLE IN OPEN PACKAGE DESIGN

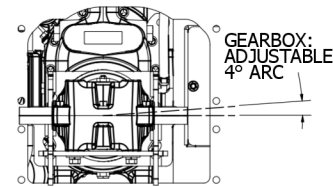

BLOWER IS AVAILABLE WITH PNEUMATIC ACTUATOR

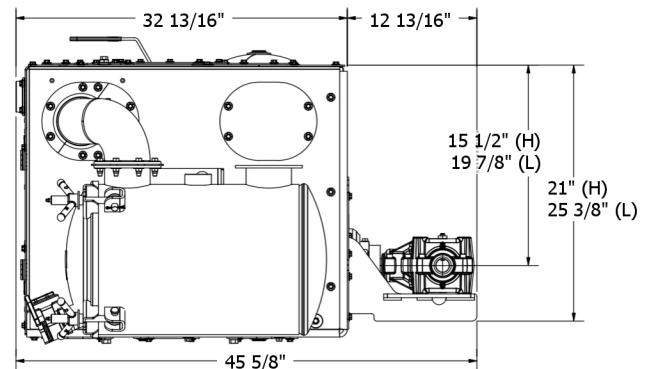

(H) HIGH SHAFT GEARBOX / (L) LOW SHAFT GEARBOX

PRODUCT DESCRIPTION	PART NUMBER	WEIGHT
4310 PRO FRAME MOUNT, HIGH SHAFT, GEARBOX DR, ENCL, SILENCER FRAME LEFT, TRAP RIGHT	147-4310HP-430-HDG	1220 LBS
4310 PRO FRAME MOUNT, LOW SHAFT, GEARBOX DR, ENCL, SILENCER FRAME LEFT, TRAP RIGHT	147-4310HP-430-LSG	1220 LBS
4310 PRO FRAME MOUNT, LOW SHAFT, GEARBOX DR, ENCL, SILENCER FRAME LEFT, TRAP RIGHT W/ ACTUATOR	147-4310HP-430-LSGA	1250 LBS
4310 PRO FRAME MOUNT, LOW SHAFT, GEARBOX DR, ENCL, SILENCER FRAME LEFT, TRAP RIGHT, ACT, VAC	147-4310HP-430-LSGAV	1250 LBS
4310 PRO FRAME MOUNT, LOW SHAFT, GEARBOX DR, ENCL, SILENCER FRAME LEFT, TRAP RIGHT, VAC (PICTURED)	147-4310HP-430-LSGV	1225 LBS
4310 PRO FRAME MOUNT, HIGH SHAFT, GEARBOX DR, ENCL, SILENCER FRAME RIGHT, TRAP LEFT	147-4310HP-431-HSG	1220 LBS
4310 PRO FRAME MOUNT, LOW SHAFT, GEARBOX DR, ENCL, SILENCER FRAME RIGHT, TRAP LEFT	147-4310HP-431-LDG	1220 LBS
4310 PRO FRAME MOUNT, LOW SHAFT, GEARBOX DR, ENCL, SILENCER FRAME RIGHT, TRAP LEFT, W/ ACTUATOR	147-4310HP-431-LDGA	1250 LBS

4310 PRO PACKAGES

MAX PRO PAK | HYDRAULIC ADAPTER

DESIGNED, BUILT & SUPPORTED IN THE USA

Challenger Series

Features

- Frame Mount with Silencers & Horizontal Moisture Trap
- SAE C face hydraulic adapter
- Hydraulic motor not included
- Improved mounting accessibility
- 3/8" powder coat painted frame
- Stainless steel cabinet with larger door
- Easily accessible service points
- Enhanced ballast and exhaust silencing for quieter operation
- Ballast check valve for pressure operation
- Blower flush kit
- L 35 5/8" W 58 1/2" H 29 3/4"

NEW PACKAGE & NEW FEATURES!
 PICTURE SHOWN WITH OPTIONAL
ADVANCED VACUUM CONTROL

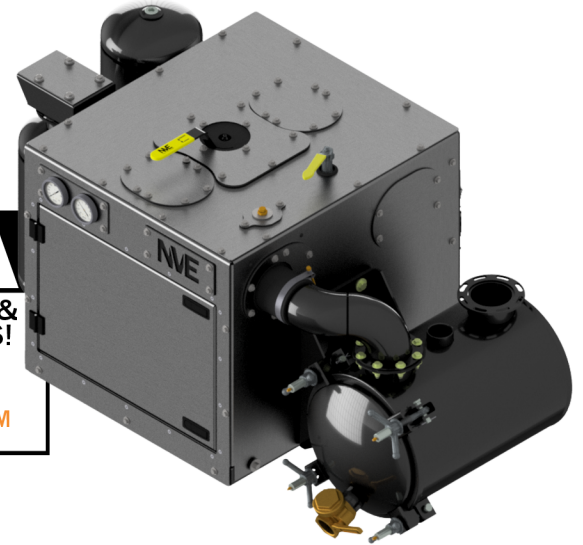

*ALSO AVAILABLE IN OPEN PACKAGE DESIGN

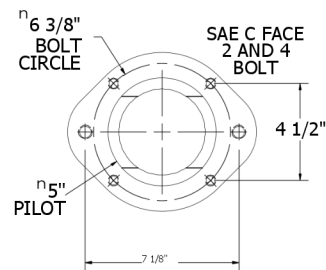
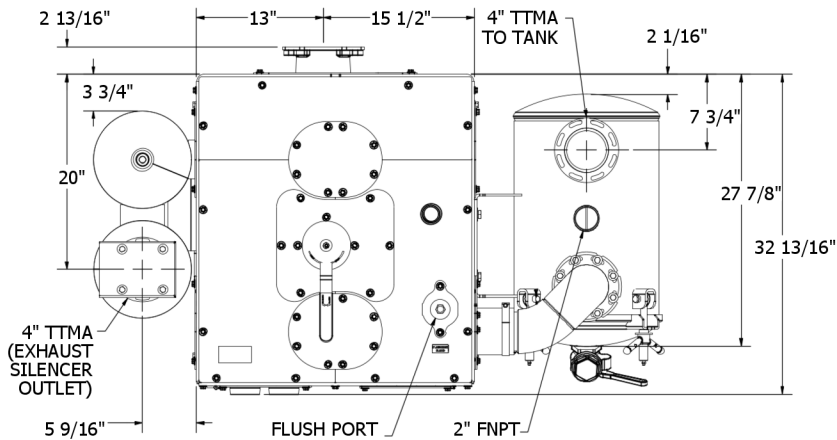

BLOWER IS AVAILABLE WITH PNEUMATIC ACTUATOR

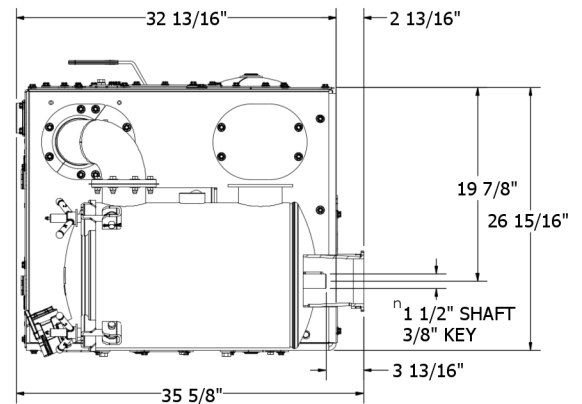
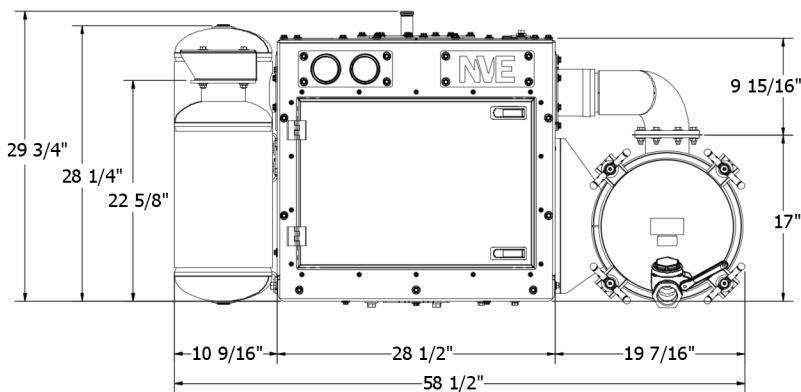

PRODUCT DESCRIPTION

4310 PRO FRAME MOUNT, LOW SHAFT, HYD DR, ENCL, SILENCER FRAME LEFT, TRAP RIGHT

PART NUMBER

147-4310HP-430-LSH

WEIGHT

1175 LBS

Features

- Frame Mount Belt Drive
- Improved mounting accessibility
- 3/8" powder coat painted frame
- Stainless steel cabinet with larger door
- Easily accessible service points
- Enhanced ballast silencing for quieter operation
- Ballast check valve for pressure operation
- Belt drive with 2.5:1 speed up ratio
- Blower flush kit
- L 46 13/16" W 39 11/16" H 29 3/4"

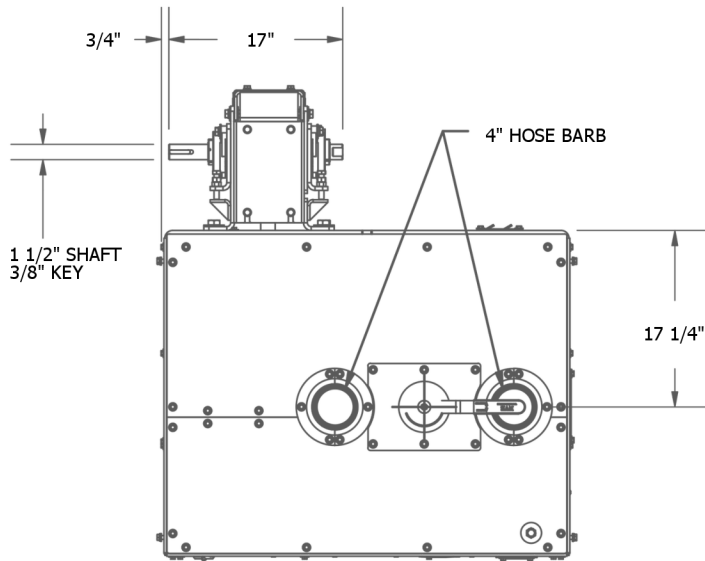
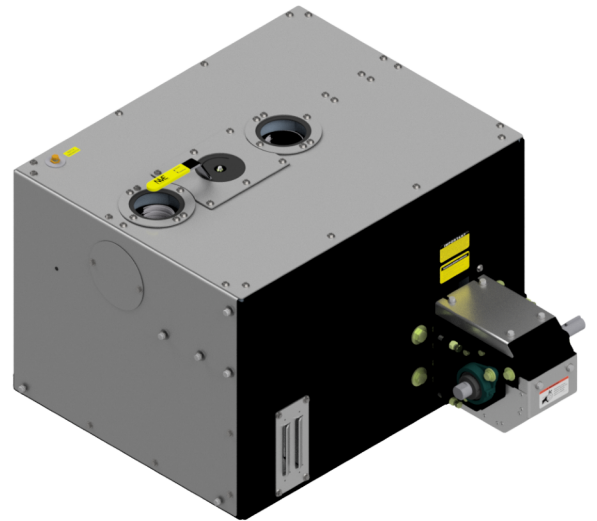

BLOWER IS AVAILABLE WITH PNEUMATIC ACTUATOR

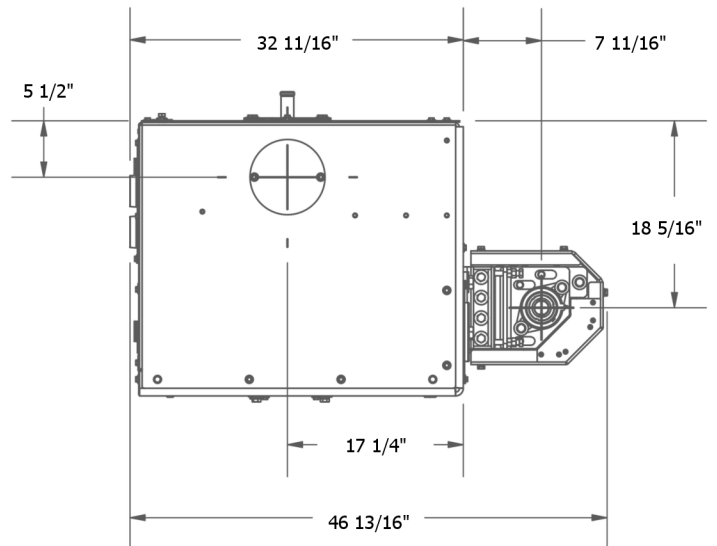
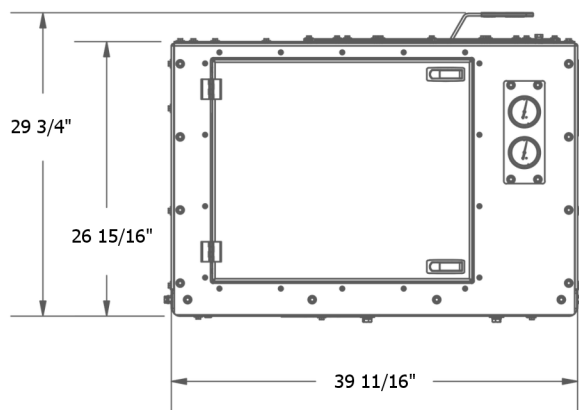

PRODUCT DESCRIPTION	PART NUMBER	WEIGHT
4310 FRAME MOUNT BELT DR CW ENCL (PICTURED)	147-4310HP-440-LDB	1027 LBS
4310 FRAME MOUNT BELT DR CCW ENCL	147-4310HP-440-HSB	1027 LBS
4310 FRAME MOUNT BELT DR CW ENCL W/ ACTUATOR	147-4310HP-440-LDBA	1052 LBS

4310 PRO PACKAGES

TOP MOUNT PRO PAK

DESIGNED, BUILT & SUPPORTED IN THE USA

Challenger Series

Features

- SAE C face hydraulic adapter or fully adjustable belt drive
- 3/8" powder coat painted frame
- Easily accessible service points
- Ballast check valve for pressure operation
- Enhanced ballast silencing for quieter operation
- Final Filter
- Blower flush kit
- Integral horizontal exhaust silencer
- Optional: Cyclone and moisture trap
- **L 81 15/16" W 36" H 67 1/8"**
(with cyclone and moisture trap)

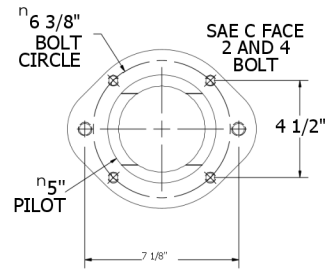
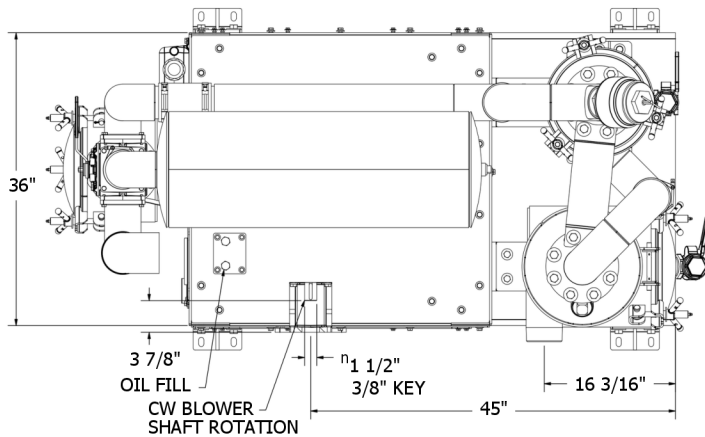
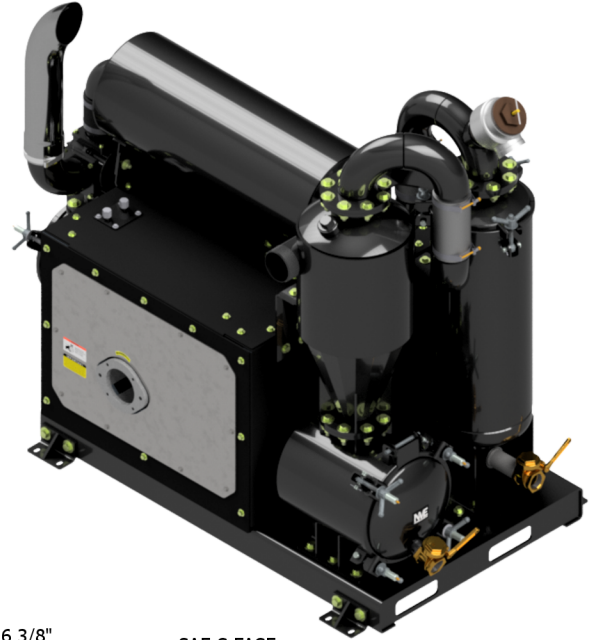

BLOWER IS AVAILABLE WITH PNEUMATIC ACTUATOR

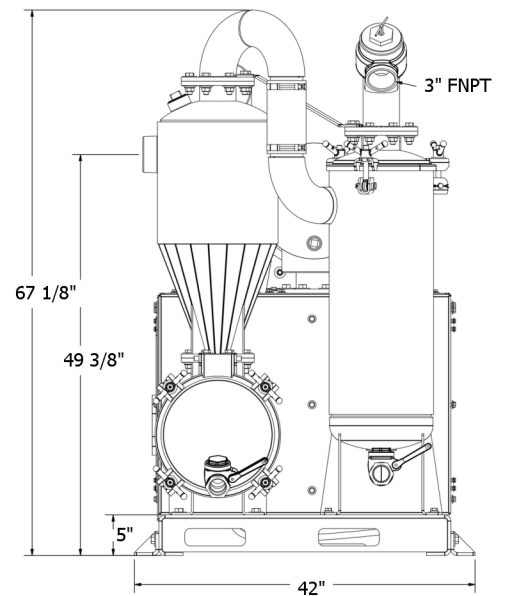
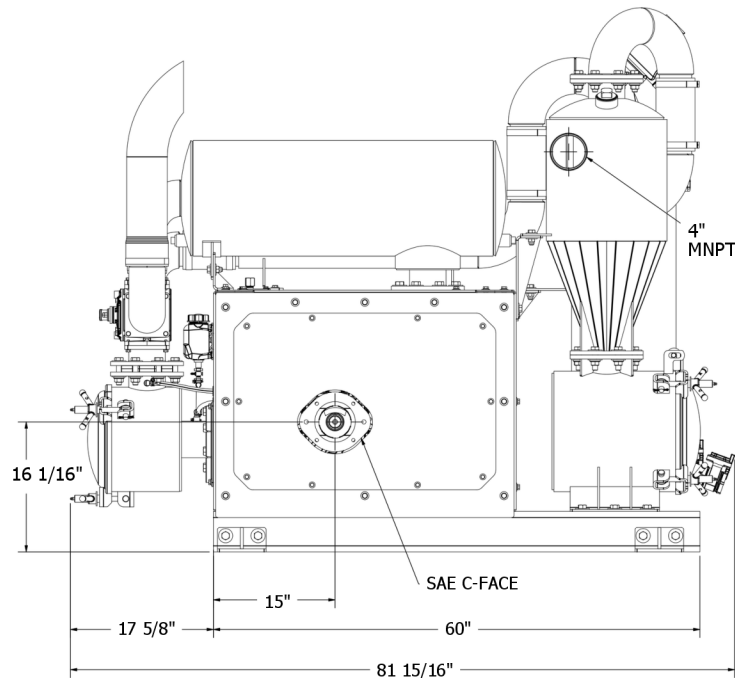

PRODUCT DESCRIPTION	PART NUMBER	WEIGHT
4310 PRO TOP MOUNT, HYD DR, ENCL	147-4310HP-600-LSH	1580 LBS
4310 PRO TOP MOUNT HYD DR, MT, CYCLONE, ENCL (PICTURED)	147-4310HP-620-HDH	2060 LBS
4310 PRO TOP MOUNT, BELT DR, MT, CYCLONE, LOW SHAFT, ENCL	147-4310HP-620-LSB	2150 LBS
4310 PRO TOP MOUNT BELT DR, MT, CYCLONE, HIGH SHAFT, ENCL	147-4310HP-620-HDB	2150 LBS

Features

- SAE C face hydraulic adapter
- Hydraulic motor not included
- 3/8" powder coat painted frame
- Easily accessible service points
- Final Filter
- Ballast check valve for pressure operation
- Enhanced ballast silencing for quieter operation
- Blower flush kit
- Integral horizontal exhaust silencer
- Enhanced silencing for quieter operation
- L 58 5/8" W 59" H 26 5/8"

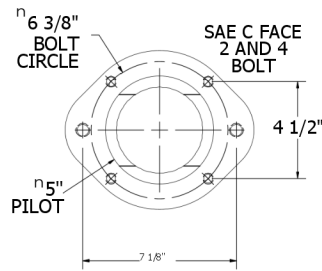
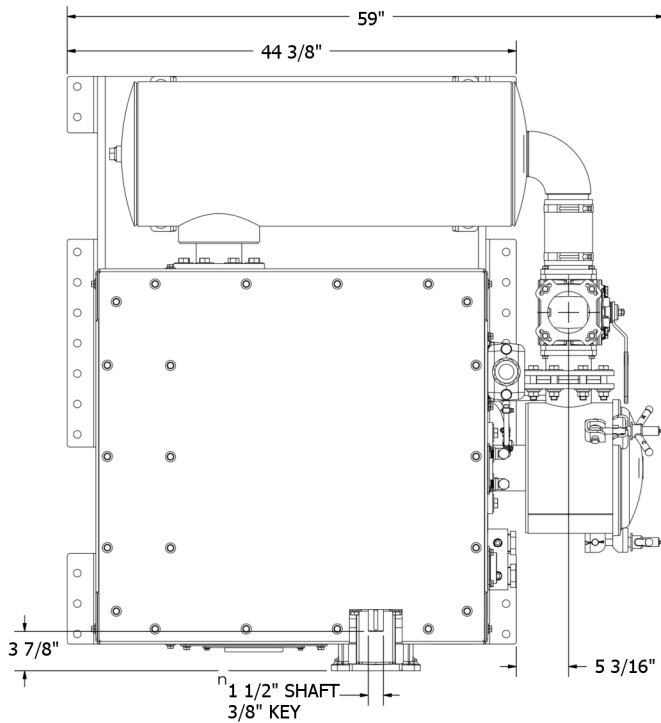
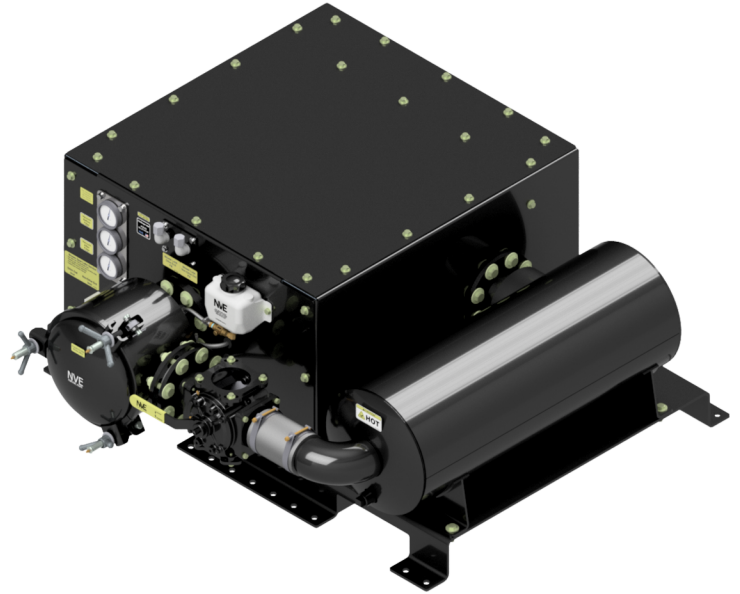

BLOWER IS AVAILABLE WITH PNEUMATIC ACTUATOR

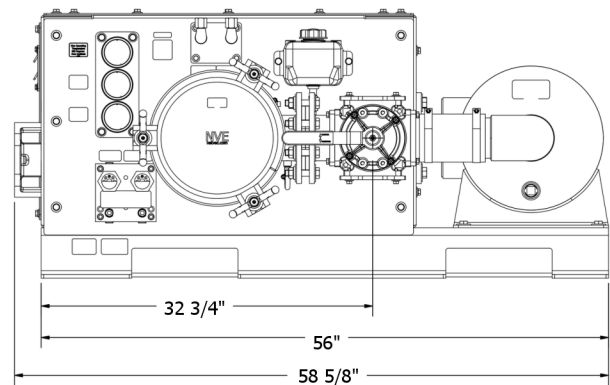
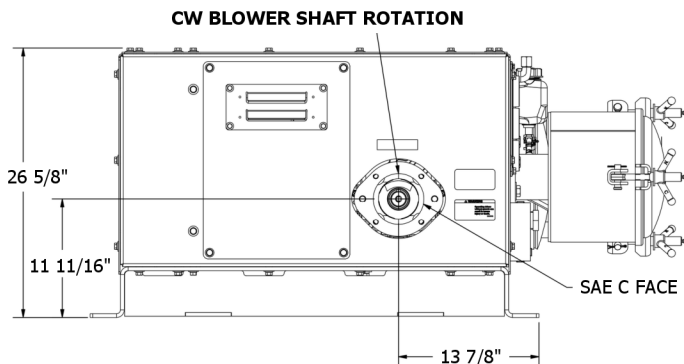

PRODUCT DESCRIPTION

4310 BELLY MOUNT HYDRAULIC DRIVE ENCLOSED

PART NUMBER

147-4310HP-800-LDH

WEIGHT

1460 LBS

4310 PRO PACKAGES

EDR / EDX

DESIGNED, BUILT & SUPPORTED IN THE USA

Challenger Series

Features

- Yanmar 69.3 HP Diesel Engine with Belt Drive
- NACD Clutch on the diesel engine
- Control panel with on /off switch
- Powder coat painted frame
- Enhance silencing for quieter operation
- Vacuum/Pressure operation
- Pressure relief 3" 10 PSI
- Battery 850 CCA
- Optional: 4 GPM Water pump @ 4000 psi
- Optional: Final filter
- L 62 5/8" W 80 5/8" H 60 5/8"

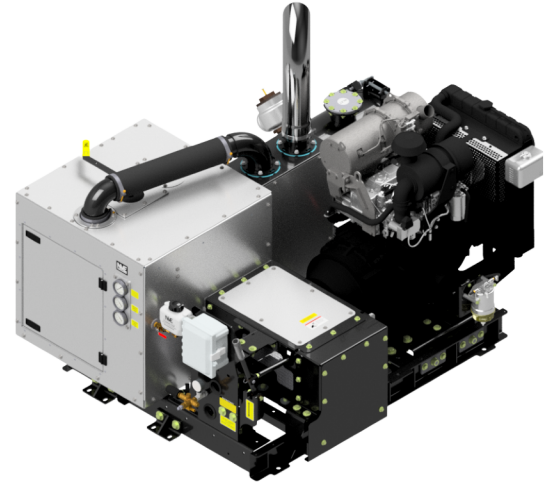

BLOWER IS AVAILABLE WITH PNEUMATIC ACTUATOR

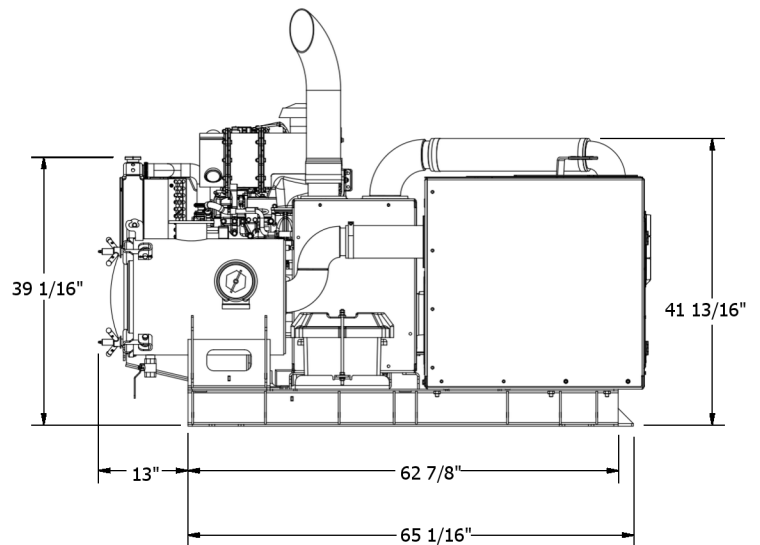
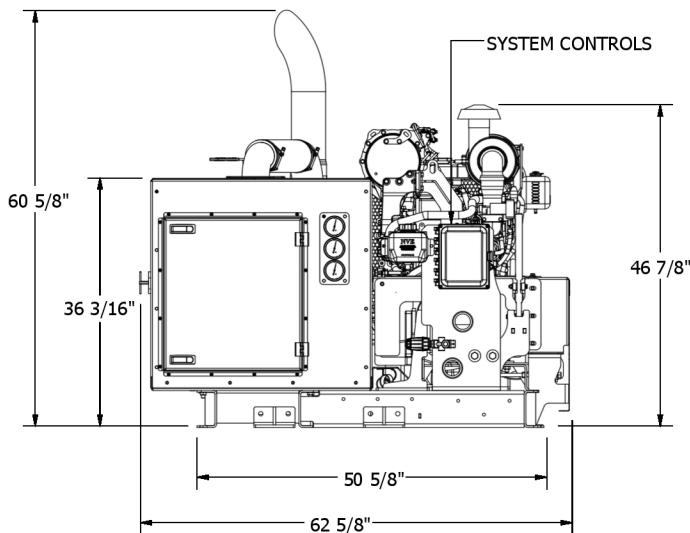
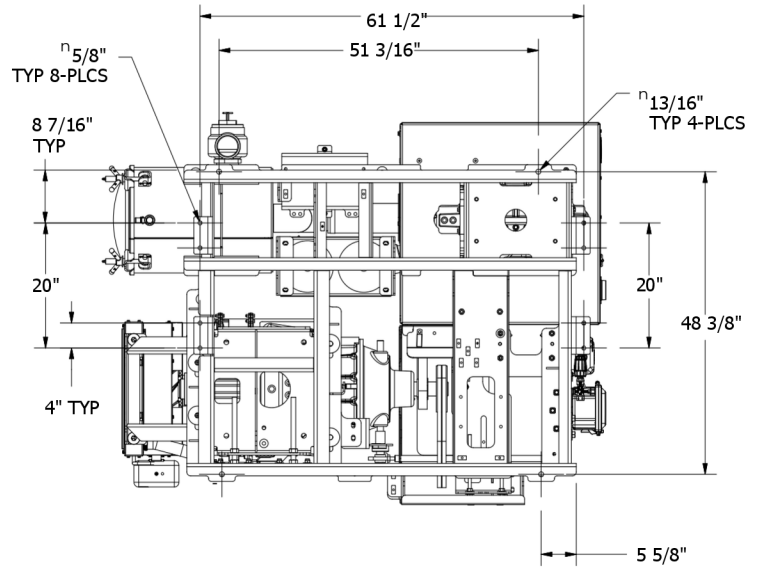
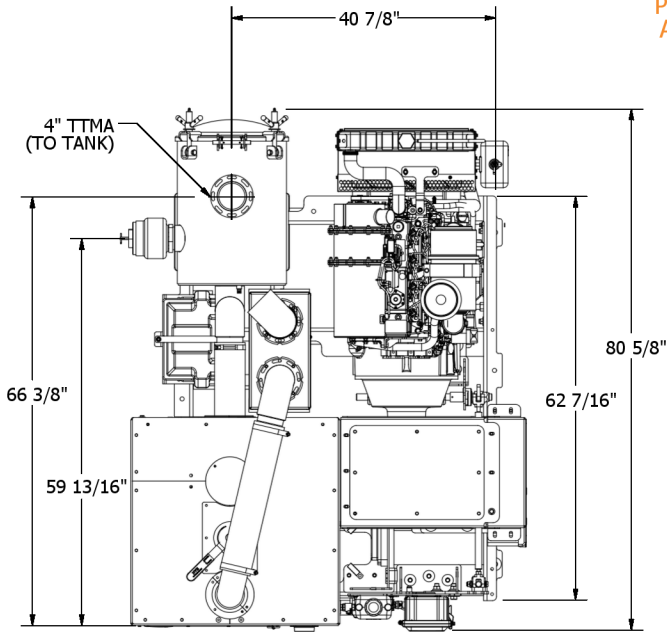

PRODUCT DESCRIPTION

4310 PRO HYDRO EXCAVATING DIESEL ENGINE DRIVE W/ HI PRESSURE PUMP (PICTURED)
 4310 PRO DIESEL ENGINE DRIVE

PART NUMBER

147-EDX-4310HP-001
 147-EDR-4310HP

WEIGHT

2700 LBS
 2670 LBS



PRODUCT DESCRIPTION	PART NUMBER	WEIGHT
GRIT RIDDER 900	222-900-1	240 LBS



PRODUCT DESCRIPTION	PART NUMBER	WEIGHT
ROUND SILENCER	224-4310-03	194 LBS

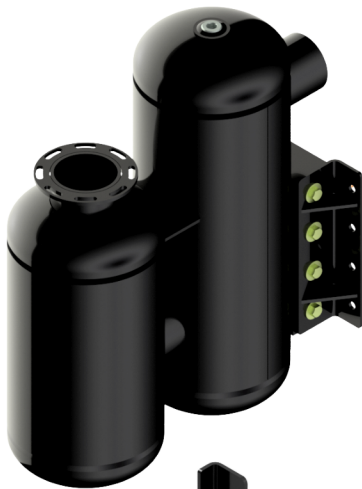

PRODUCT DESCRIPTION	PART NUMBER	WEIGHT
43 SERIES PRO EXHAUST SILENCER, FRAME MOUNT	224-360-025	110 lbs
43 SERIES PRO EXHAUST SILENCER, RH INLET	224-360-024	96 lbs
43 SERIES PRO EXHAUST SILENCER, LH INLET	224-360-023	96 lbs



PRODUCT DESCRIPTION	PART NUMBER	WEIGHT
HORIZONTAL MOISTURE TRAP	218-140-001	87 LBS



PRODUCT DESCRIPTION	PART NUMBER	WEIGHT
14 GAL MOISTURE TRAP ALU 4" NPT	216-140-4NPT-A	70 LBS
14 GAL MOISTURE TRAP CARBON 4" NPT	216-140-4NPT-C	131 LBS
14 GAL MOISTURE TRAP SS 4" NPT	216-140-4NPT-S	131 LBS
25 GAL MOISTURE TRAP ALU 4" NPT	216-250-4NPT-A	93 LBS
25 GAL MOISTURE TRAP CARBON 4"	216-250-4NPT-C	171 LBS
25 GAL MOISTURE TRAP SS 4" NPT	216-250-4NPT-S	171 LBS

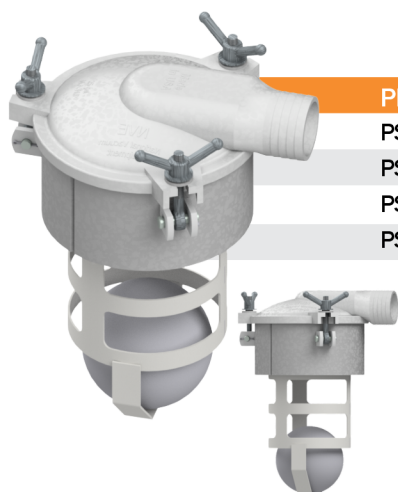

PRODUCT DESCRIPTION	PART NUMBER	WEIGHT
PSO 12" X 6" CARBON BASE ALU LID 4" HB 10" CAGE	200-1206-4HB-10	50 LBS
PSO 12" X 6" ALU BASE ALU LID 4" HB 10" CAGE	204-1206-4HB-10	42 LBS
PSO 12" X 6" ALU BASE SS LID 4" NPT 10" CAGE	204-1206-4NPT-10	55 LBS
PSO 12" X 6" SS BASE ALU LID 4" HB 10" CAGE	208-1206-4HB-10	55 LBS



PRODUCT DESCRIPTION	PART NUMBER	WEIGHT
PSO 20" X 6" CARBON BASE & LID 4" NPT 10" CAGE	202-2006-4NPT-10	95 LBS



PRODUCT DESCRIPTION	PART NUMBER	WEIGHT
COUPLER HUB E20 1 3/8"	424-200-1375	7.25 LBS
COUPLER HUB E20 1 1/2"	424-200-150	7.25 LBS
COUPLER FLEX ELEMENT E20	424-200-E20	4.15 LBS

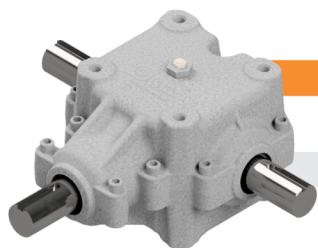

PRODUCT DESCRIPTION	PART NUMBERS	WEIGHT
4310 GEARBOX 500 SERIES 1:2 RATIO SPIRAL BEVEL GEARS WITH 1 3/8" SHAFT	422-500-2	28.3 LBS
4310 WELDED GEARBOX BRACKET	280-401-005	31 LBS

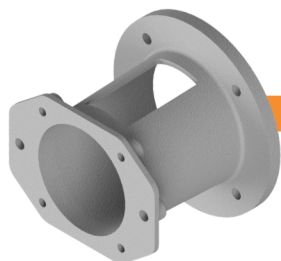

PRODUCT DESCRIPTION	PART NUMBER	WEIGHT
HYDRAULIC ADAPTER 43 SERIES, SAE C-FACE	150-466-004	5.5 LBS



PRODUCT DESCRIPTION	PART NUMBER	WEIGHT
BLOWER PACKAGE FLUSH KIT (REMOTE)	320-081-013	2 LBS
FLUSH TANK ASSY HDPE 1QT	320-082-003Z	2 LBS
OIL TANK CAP BLACK W/TETHER	320-083-002	0.10 LBS
OIL LINE BLK 1/4" ID 30R7 PER FT.	320-407-003	0.4 LBS



PRODUCT DESCRIPTION	PART NUMBER	WEIGHT
FLANGE 4" ADJUSTABLE ELBOW	150-063-014	1.50 LBS
O-RING VITON FOR ELBOW	120-064-012	.01 LBS
ELBOW 4" 90 DEGREE ALUM. HOSE BARB X O-RING	803-063-001	2.00 LBS
ELBOW 4" 90 DEGREE ALUM. HOSE BARB X HOSE BARB	803-063-012	.69 LBS

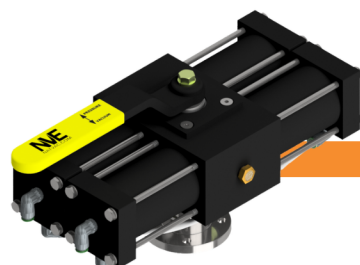

PRODUCT DESCRIPTION	PART NUMBER	WEIGHT
3 POSITION PNEUMATIC ACTUATOR	409-200-100	25 LBS



PRODUCT DESCRIPTION	PART NUMBER	WEIGHT
4310 PRO INLET FILTER	150-314-012	1.10 LBS
4310 PRO FILTER FOR REMOTE 12" FINAL FILTER	150-314-008	7 LBS



PRODUCT DESCRIPTION	PART NUMBER	WEIGHT
KNOB - FILTER COVER 5/16-18 UN	120-312-002	.10 LBS



PRODUCT DESCRIPTION	PART NUMBER	WEIGHT
THERMOMETER REMOTE 200-400F 6' COPPER LEAD 3/8"	408-200-006	1.25 LBS
GAUGE 2.5" VAC/PRES LIQ BACK CONNECTION 1/4 NPT	408-200-007	.45 LBS

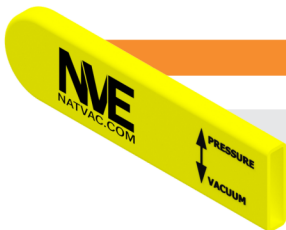

PRODUCT DESCRIPTION	PART NUMBER	WEIGHT
HANDLE 4310 PRO ENCLOSED	412-060-009	2 LBS
YELLOW GRIP 1/4" HANDLE W/ LOGO	120-060-002	.05 LBS



PRODUCT DESCRIPTION	PART NUMBER	WEIGHT
VALVE 4" 4-WAY ASSY NO FLANGES	410-004-002-NF	35.3 LBS



National Vacuum Equipment
■ Part of Atlas Copco Group



Revised 11/2025

Challenger Series

800-253-5500
sales@natvac.com
2707 Aero Park Dr. | Traverse City, MI 49686

PRODUCT
INFORMATION



CONDITION
OF SALES

