

NVE

National Vacuum Equipment



B250 VACUUM BLOWER

PRODUCT CATALOG

Challenger Series
VACUUM PUMPS & BLOWERS



Designed. Built. Supported in The USA.

800-253-5500 | www.natvac.com

B250 Blower	3
B250 Frame Mount Blower Package.....	4
B250 Engine Drive Package	5
B250 Components & Accessories	6

CONDITION OF SALES

To view NVE’s Condition of Sales, scan the QR Code to the right of this text with your phone’s camera or visit <https://natvac.com/ordering-information/>



B250 Blower

Features

- Oil-less operation
- Built in vacuum/pressure change over valve
- Easily accessible grease points
- Exhaust temperature gauge
- Vented oil sump caps
- Highly efficient three lobe rotor design
- Blower flush kit included
- Designed, built, and supported in the USA

B250 CHALLENGER BLOWER | SPECIFICATIONS

*Operating Range - RPM	1800	2200	2600
Max Airflow	215	240	285
Maximum Horse Power	12	15	20
*Maximum Vacuum	15" HG		
Maximum Pressure	15 PSI		
Porting Size	2"		
Shaft Size (5/16" Key)	1 3/8"		
Approximate Weight	241 lbs		

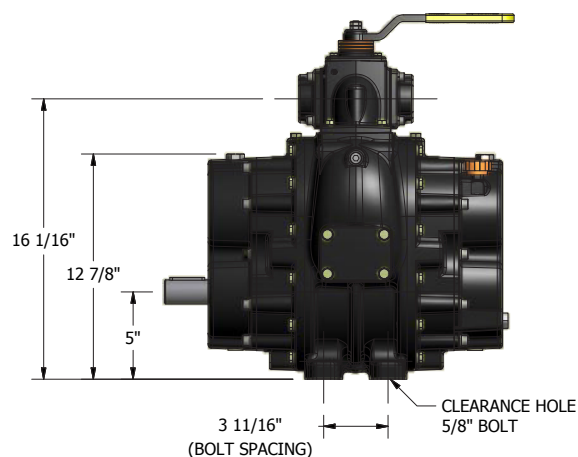
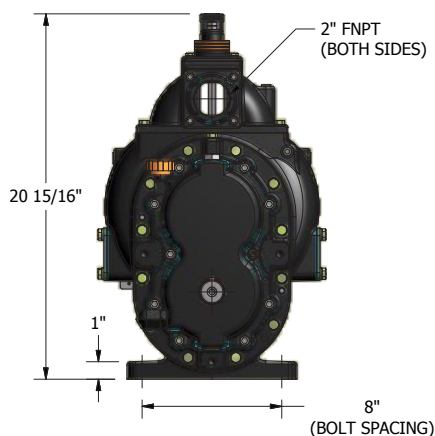
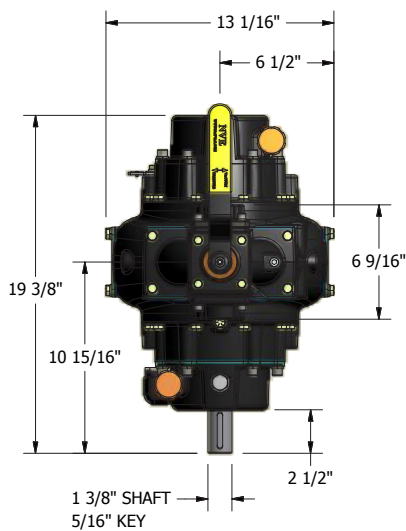

PRODUCT DESCRIPTION

Blower B250, Low Shaft, CCW, Manifold

PART NUMBER

131-B250-LSM

WEIGHT

241 lbs

*The maximum allowable operating vacuum will vary depending on R.P.M., ambient temperature, altitude and time running. The basic principle to keep in mind is - faster R.P.M., higher air temperature and longer run time all equal more heat in blower. When installing an NVE B250 blower we recommend a normal R.P.M. of 2200. Other speeds are ok as long as exhaust gas temperatures read on the supplied thermometer do not exceed 380 degrees F.

Features

- B250 tri-lobe blower with 4 way vacuum/pressure change over valve
- 1:1.5 speed increasing gearbox
 - Available with hydraulic adapter SAE A or B face
- Pre-filter cleanable stainless steel
- Horizontal moisture trap
- Blower flush kit
- Vacuum and pressure relief
- Vacuum pressure gauge
- Temperature gauge

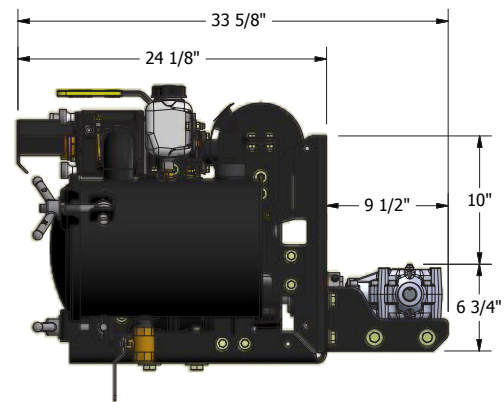
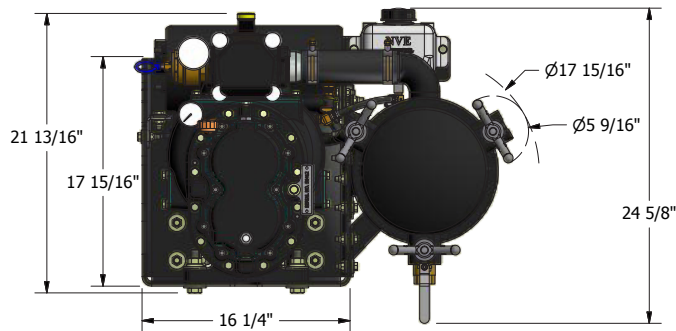
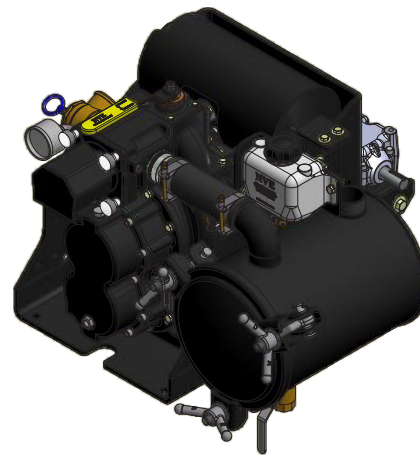
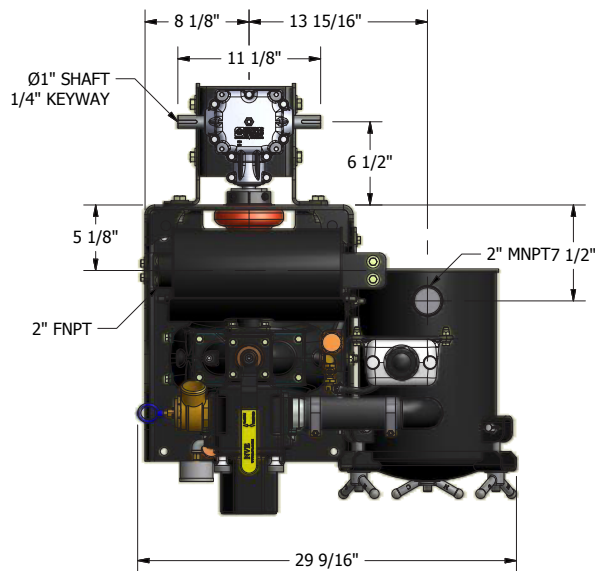

PRODUCT DESCRIPTION	PART NUMBER	WEIGHT
B250 Frame Mount Gearbox Drive, RH MT & Exhaust Silencer Package	147-B250-001	492 lbs
B250 Frame Mount Hydraulic Drive A Face, RH MT & Exhaust Silencer Package	147-B250-002	457 lbs
B250 Frame Mount Hydraulic Drive B Face, RH MT & Exhaust Silencer Package	147-B250-003	457 lbs



B250 Engine Drive Package

Features

- B250 tri-lobe blower with 4 way vacuum/pressure change over valve
- Briggs and Stratton 23 HP Electric Start Engine
- Powder Coat Painted and Factory Assembled
- Belt and Pulley Drive
- 12 Volt high crank capacity Battery
- Exhaust Silencer
- Flush Kit

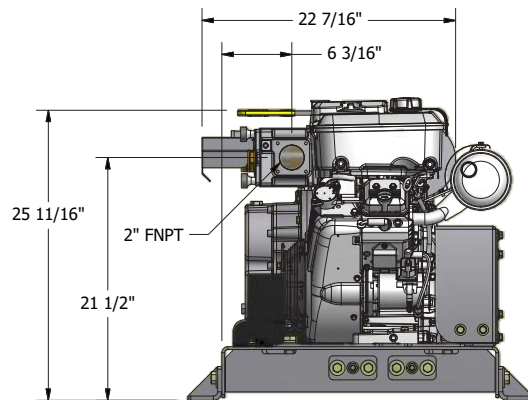
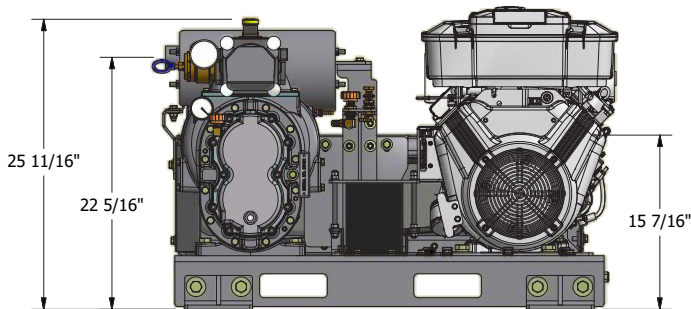
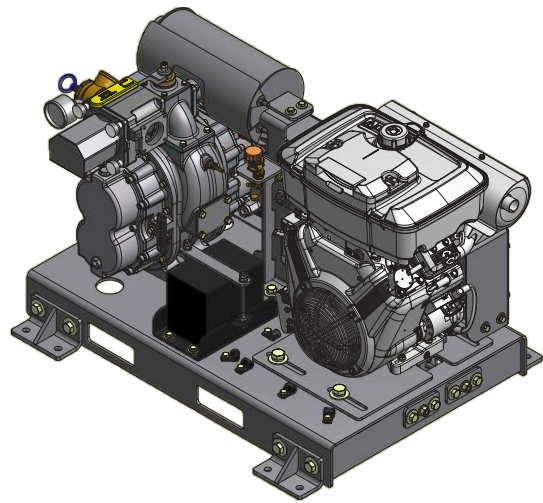
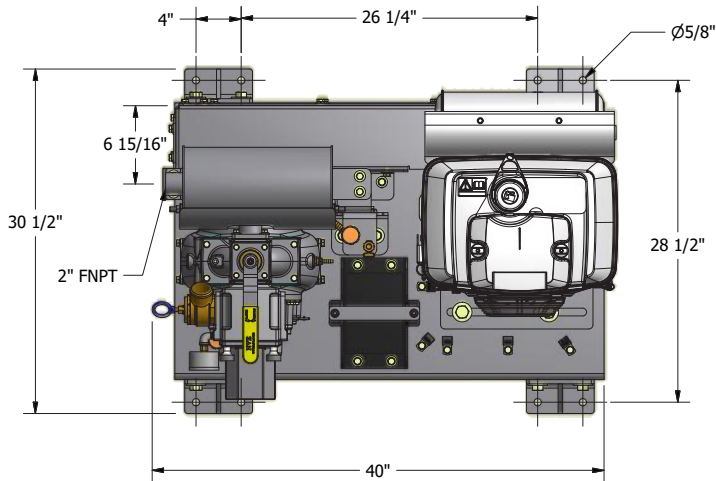

PRODUCT DESCRIPTION	PART NUMBER	WEIGHT
B250 with 23 HP Briggs & Stratton Gas Engine	147-B250-005	614 lbs

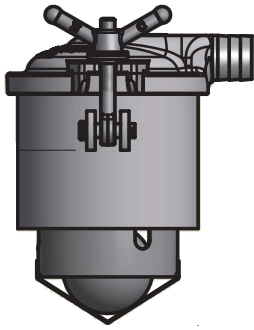

PRODUCT DESCRIPTION	PART NUMBER	WEIGHT
Primary Shutoff 8" X 6" Carbon Base Cast 2" Hb	200-0806-2HB	25 lbs
Primary Shutoff 8" X 6" Alu Base Cast Alu Lid 2" HB	204-0806-2HB	17.3 lbs
Primary Shutoff 8" X 6" SS Base Cast Alu Lid 2" HB	208-0806-2HB	25.4 lbs

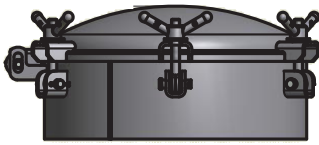

PRODUCT DESCRIPTION	PART NUMBER	WEIGHT
Portal Carbon 12" X 6" GOL	200-1206-C	37 lbs
Portal 12" X 6", Alu Base SS Lid GOL	204-1206-A	21 lbs
Manway Carbon 17" X 6" GOL	202-1706-C	48 lbs
Manway Carbon 20" X 6" GOL	202-2006	72 lbs
Manway Alu 20" X 6" W/ Cast Al Lid GOL	206-2006-A	42 lbs



PRODUCT DESCRIPTION	PART NUMBER	WEIGHT
Secondary Shutoffs Mt 4 Gal Alu 2" HB	216-400-2NPT-A	23 lbs
Secondary Shutoffs Mt 4 Gal 2" NPT	216-400-2NPT-C1	30 lbs
Secondary Shutoffs Mt 4 Gal SS Alu Lid 2" HB	216-400-2NPT-S	30 lbs

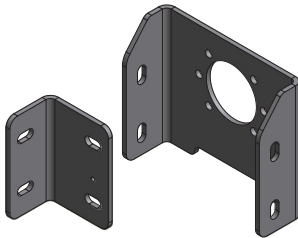

PRODUCT DESCRIPTION	PART NUMBER	WEIGHT
B250 Hyrdaulic Adapter Kit Sae A Face	280-355-219	17 lbs
B250 Hyrdaulic Adapter Kit Sae B Face	280-355-226	15 lbs

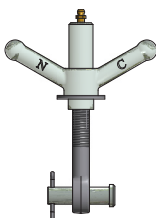

PRODUCT DESCRIPTION	PART NUMBER	WEIGHT
Wingnut, Eyebolt Clevis & Cotter Pin (Qty 6)	284-KIT-C	1.5 lbs
Lubenut, Eyebolt, Clevis & Cotter Pin (Qty 6)	284-KIT-CLN	1.6 lbs

B250 Components & Accessories

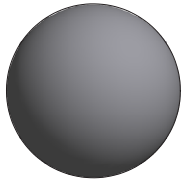

PRODUCT DESCRIPTION	PART NUMBER	WEIGHT
Float Balls 4" SS	414-400-SS	0.5 lbs



PRODUCT DESCRIPTION	PART NUMBER	WEIGHT
Gasket 12" Lid And Neck Buna	286-706-12L	0.7 lbs
Gasket 17" Lid Buna	286-706-17L	1 lbs
Gasket 19.5" Lid Buna	286-706-20L	1 lbs

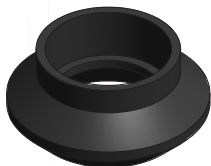

PRODUCT DESCRIPTION	PART NUMBER	WEIGHT
Ball Seat 3" Buna	416-300-B	0.6 lbs
Clamp Worm 3" Ball Seats	416-300-1WC	0.1 lbs

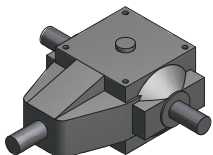

PRODUCT DESCRIPTION	PART NUMBER	WEIGHT
Gear Box 200 Series 1:1.5	422-200-3	15 lbs



PRODUCT DESCRIPTION	PART NUMBER	WEIGHT
Coupler Hub E5 1" Bore 1/4" Key	424-050-100	3 lbs
Coupler Hub E5 1 3/8" Bore 5/16" Key	424-050-1375	3 lbs
Coupler Flex Element E5	424-050-E5	2 lbs

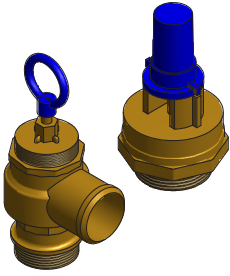

PRODUCT DESCRIPTION	PART NUMBER	WEIGHT
Vacuum Relief 1 1/2" NPT	366-150	1.1 lbs
Pressure Relief 1.50"	364-306-015	1.85 lbs
Pressure Relief 1.25"	364-306-1.25	1.45 lbs
Pressure Relief 2"	364-306-2	2.7 lbs

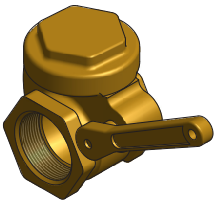

PRODUCT DESCRIPTION	PART NUMBER	WEIGHT
Lever Valve 2"	362-301-2	3.9 lbs
Lever Valve 3"	362-301-3	8.7 lbs
Lever Valve 3" TTMA/NPT	362-301-3T	10 lbs
Lever Valve 4"	362-301-4	12 lbs



PRODUCT DESCRIPTION	PART NUMBER	WEIGHT
Elbow 2" 90 Degree Alum Hose Barb X Hose Barb	803-063-014	0.5 lbs

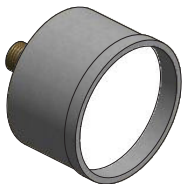

PRODUCT DESCRIPTION	PART NUMBER	WEIGHT
Gauge 2.5" Vac/Press Liq Back Conn 1/4" NPT	408-200-009	.45 lbs



PRODUCT DESCRIPTION	PART NUMBER	WEIGHT
Tank Assy HDPE 1QT	320-082-003Z	.50 lbs

B250 Components & Accessories

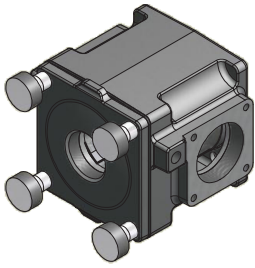

PRODUCT DESCRIPTION	PART NUMBER	WEIGHT
Filter Box Assembly B250	120-318-001	5 lbs

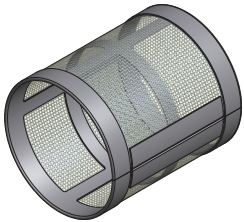

PRODUCT DESCRIPTION	PART NUMBER	WEIGHT
Intake Filter B250	120-314-004	.35 lbs



PRODUCT DESCRIPTION	PART NUMBER	WEIGHT
O-Ring Square 7-342NBR-70	120-064-033	.39 lbs



PRODUCT DESCRIPTION	PART NUMBER	WEIGHT
Gasket Filter Cover B250	120-315-001	4.09 lbs

DESIGNED. BUILT. SUPPORTED.

Produced in the USA | Distributed World-Wide



800-253-5500
sales@natvac.com
2707 Aero Park Dr. | Traverse City, MI 49686

NVE
National Vacuum Equipment
Challenger **Series**
VACUUM PUMPS & BLOWERS