

4310 PRO

Helical Tri-Lobe Heavy Duty Vacuum Blower

PRODUCT BROCHURE



FEATURES

- Continuous duty performance at maximum vacuum
- Oil-less operation
- Range of airflow - performance available to accommodate power
- Helical tri-lobe rotors engineered to increase efficiency, lower pulsations, and reduce noise
- Vacuum and pressure change over valve
- Adjustable 4" elbows with hose barbs for intake and exhaust ports
- Ballast Port manifold - cools blower through air injection
- Built-in ballast check valve
- Oil level inspection sight eyes
- Improved, longer lasting final filter
- Improved Serviceability
 - End plate design
 - Flushing ports and drain plugs
 - Carrier for sump seal

4310 PRO CHALLENGER BLOWER | SPECIFICATIONS

Air Flow - Free Air	940 CFM at 4500 RPM	
*Full Vacuum	-	
Maximum Intermittent Pressure	15 PSI	
*Operating Speed - recommended	4000 RPM	4500 RPM
HP Required @ 27" Hg	51.4	58
HP Required @ 10 psi	39.7	44
HP Required @ 15 PSI	65.5	-
Porting Size	4"	
Shaft Size (3/8" Key)	1 1/2"	
Approximate Weight	456 lbs	

Designed, Built and Supported in the USA

*The maximum allowable operating vacuum will vary depending on R.P.M., ambient temperature, altitude and time running. The basic principle to keep in mind is - faster R.P.M., higher air temperature and longer run time all equal more heat in blower. When installing a 4310 PRO blower we recommend a normal R.P.M. of 4000. Other speeds are OK as long as exhaust gas temperatures read on the supplied thermometer do not exceed 380 degrees F. Maximum of 4500 R.P.M is for intermittent use only.

Weights & Measurements are for reference only. Prices subject to change at any time | Revised 03/2026

4310 PRO

Helical Tri-Lobe Heavy Duty Vacuum Blower



OPEN PACKAGE OPTION

Features

- Frame Mount
- 500 series 1:2 ratio gearbox
- Optional: Silencers (pictured) and/or Moisture Trap
- 3/8" powder coat painted frame
- Easily accessible service points
- Blower flush kit
- Enhanced ballast and exhaust silencing for quieter operation
- Ballast check valve for pressure operation
- L 44 9/16" W 38 15/16" H 29 11/16"

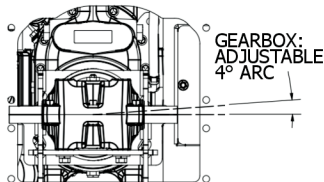

BLOWER IS
AVAILABLE WITH
PNEUMATIC
ACTUATOR

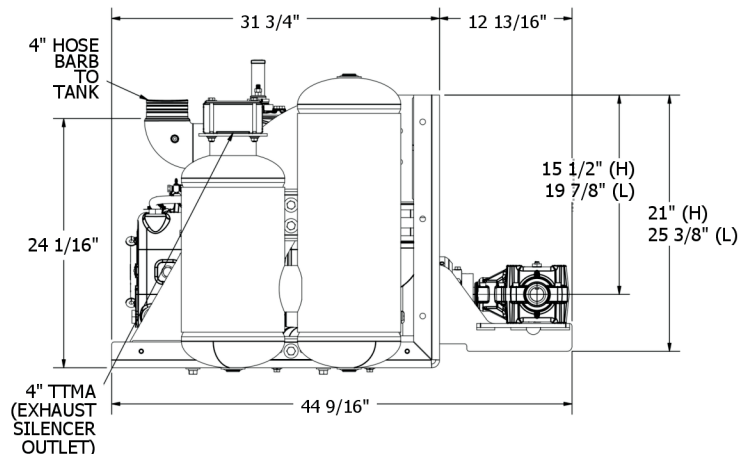
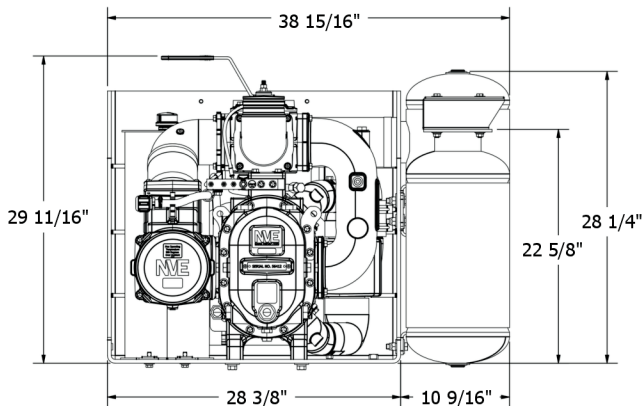
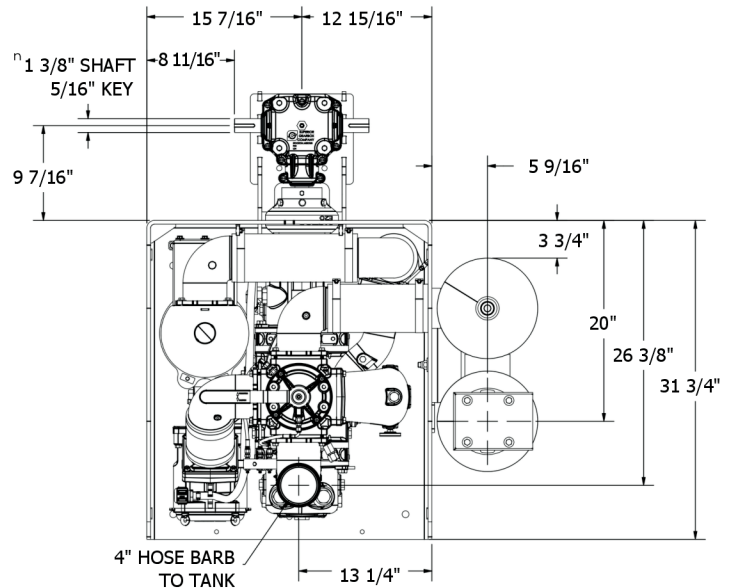

4310 PRO BLOWER

Open Package Options

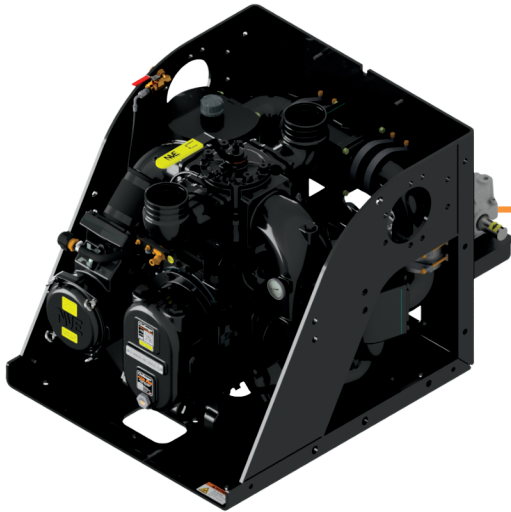

OPEN PAK

Frame Mount
Gearbox or Hydraulic Drive

- 3/8" powder coat painted frame
- Easily accessible service points
- Blower flush kit
- Enhanced silencing for quieter operation
- Optional: Silencers (pictured) and Moisture Trap
- 1:2 ratio gearbox or SAE C face hydraulic adapter
- L 44 9/16" W 38 15/16" H 29 11/16"

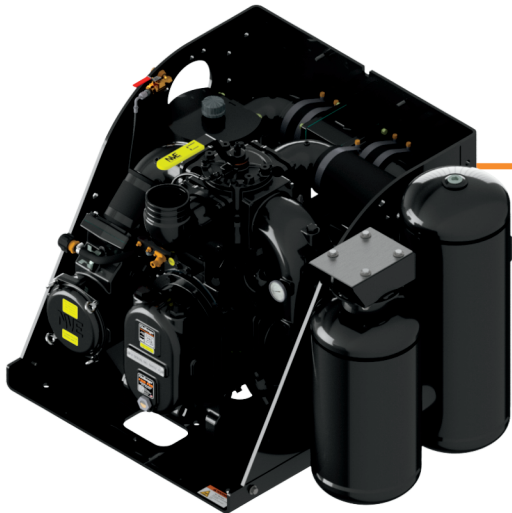

OPEN SILENCER PRO PAK

Frame Mount with Silencers
Gearbox or Hydraulic Drive

- Improved mounting accessibility
- 3/8" powder coat painted frame
- Stainless steel cabinet with larger door
- Easily accessible service points
- Blower flush kit
- Enhanced silencing for quieter operation
- 1:2 ratio gearbox or SAE C face hydraulic adapter
- L 45 5/8" W 39 1/2" H 29 11/16"



OPEN MAX PRO PAK

Frame Mount with Silencers & Moisture Trap
Gearbox or Hydraulic Drive

- Improved mounting accessibility
- 3/8" powder coat painted frame
- Stainless steel cabinet with larger door
- Easily accessible service points
- Blower flush kit
- Enhanced silencing for quieter operation
- Horizontal moisture trap
- 1:2 ratio gearbox or SAE C face hydraulic adapter
- L 45 5/8" W 58 1/2" H 29 11/16"

NVE

800-253-5500 | sales@natvac.com

Challenger Series



National Vacuum Equipment
■ Part of Atlas Copco Group



Revised 03/2026

Challenger Series

800-253-5500

sales@natvac.com

2707 Aero Park Dr. | Traverse City, MI 49686

PRODUCT
INFORMATION



CONDITION
OF SALES

