

NVE

National Vacuum Equipment

■ Part of Atlas Copco Group



MADE IN THE USA

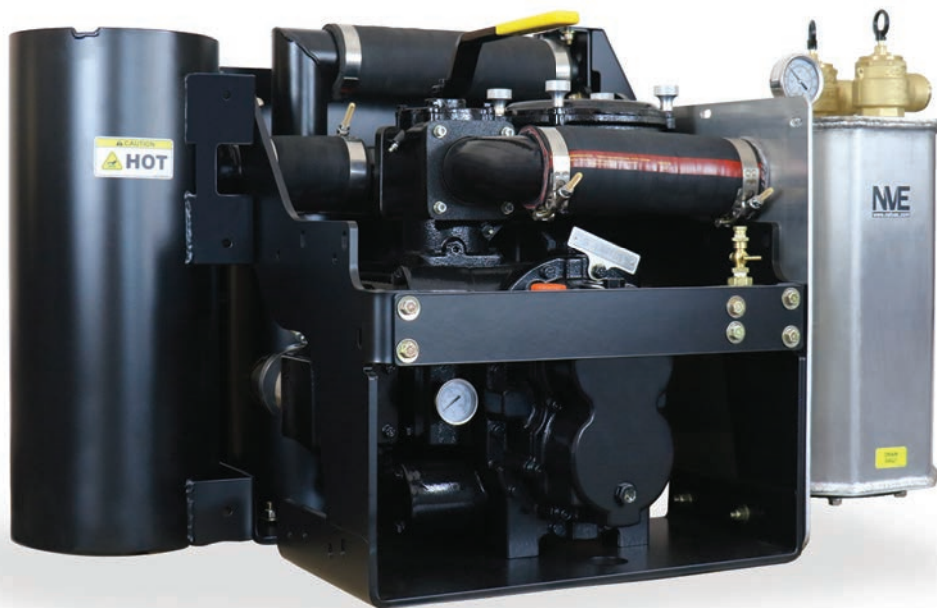

B500 VACUUM BLOWER

PRODUCT CATALOG

800-253-5500
www.natvac.com

Challenger Series
VACUUM PUMPS & BLOWERS

B500 Blower..... 3

B500 Silencer Package..... 4

B500 Max Package..... 5

B500 Components & Accessories..... 6



National Vacuum Equipment
 ■ Part of Atlas Copco Group

800-253-5500
 sales@natvac.com
 2707 Aero Park Dr. | Traverse City, MI 49686

NVE Product Information



Condition of Sales





MADE IN THE USA

B500 Blower

Features

- Proven air injection cooling
- Oil-less operation
- Built in vacuum/pressure change over valve
- Easily maintainable pre filter
- Easily accessible grease points
- Continuous duty to 24" HG
- Highly efficient three lobe rotor design
- Blower flush kit included
- Designed, built, and supported in the USA

B500 CHALLENGER BLOWER | SPECIFICATIONS

*OPERATING RANGE - RPM	2400
MAXIMUM AIRFLOW	431
MAXIMUM HORSE POWER	30
*MAXIMUM VACUUM	24" HG
MAXIMUM PRESSURE	15 PSI
PORTING SIZE	3"
SHAFT SIZE (5/16" Key)	1 3/8"
APPROXIMATE WEIGHT	370 LBS

The B500 is an entry vacuum blower designed to be used with a 3" plumbed system with a maximum recommended operation of 2400 RPM.

At 2400 RPM it is capable of 431 CFM free air, 80% efficient, and able to generate 24" hg corrected to sea level. It is able to run at maximum vacuum with no vacuum relief valve required.

The B500 silencing system is able to limit exhaust noise and should require no additional silencing to yield acceptable acoustic performance.

Because the B500 is an entry level machine designed to be used with 3" plumbing, it is not recommended for the machine be operated at a higher RPM.

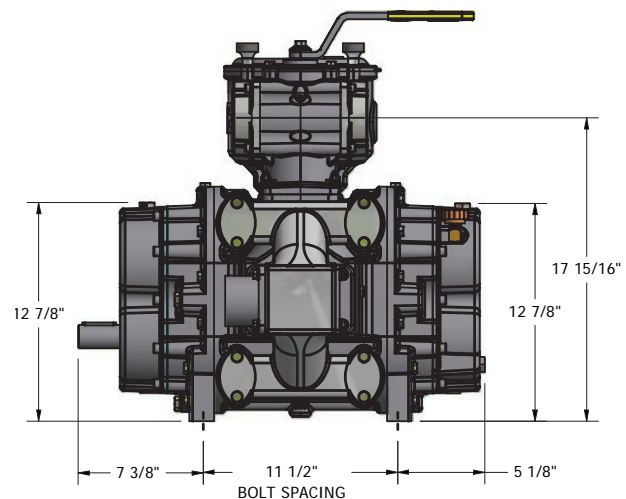
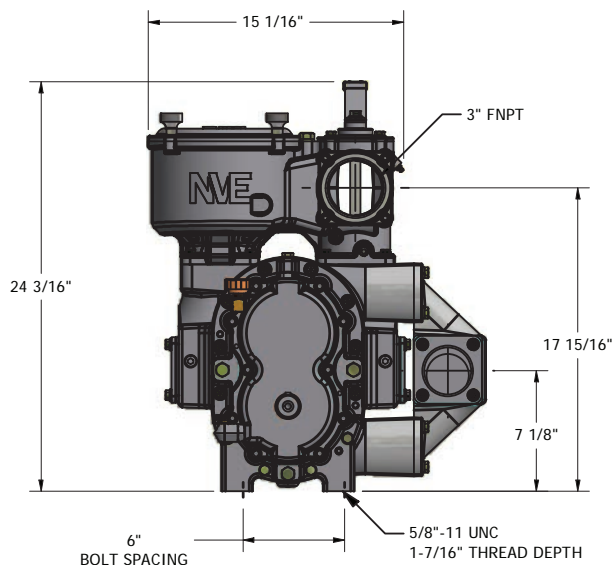
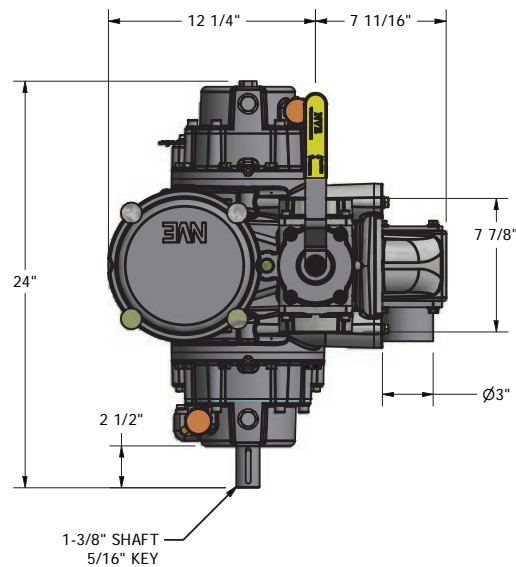

PRODUCT DESCRIPTION	PART NUMBER	WEIGHT
Blower B500, Low Shaft, CCW, Manifold	131-B500-LSM	370 lbs

*The maximum allowable operating vacuum will vary depending on R.P.M., ambient temperature, altitude and time running. The basic principle to keep in mind is - faster R.P.M., higher air temperature and longer run time all equal more heat in blower. When installing a NVE B500 blower we recommend a normal R.P.M. of 2400. Other speeds are ok as long as exhaust gas temperatures read on the supplied thermometer do not exceed 380 degrees F.

Features

- B500 high vacuum tri-lobe blower with 4-way vacuum pressure change over valve
- Oil-less operation
- Exhaust air silencer
 - Can be mounted in any position
- Ballast air silencer
- 1:2 speed increasing right angle gearbox
- Clockable gearbox bracket for easy matching of driveline angles
- E20 coupler set
- All elbows, fittings, and high temp hose are factory connected
- Flows up to 431 CFM
- Designed, built, and supported in the USA

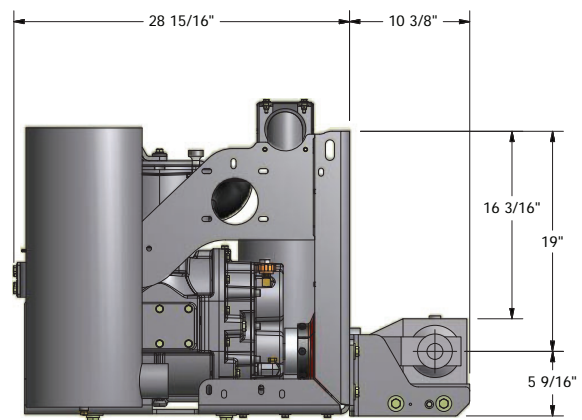
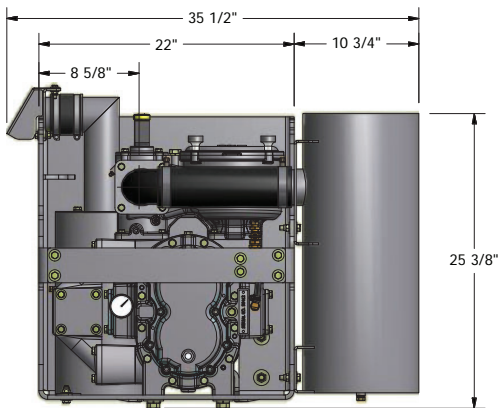
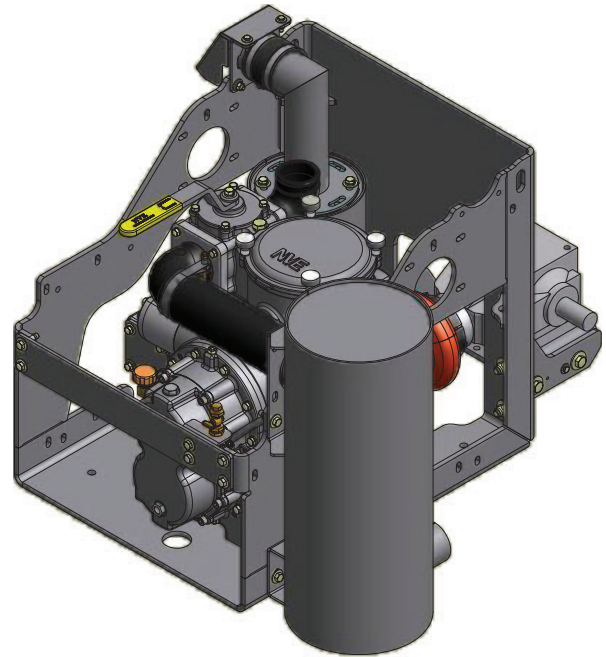
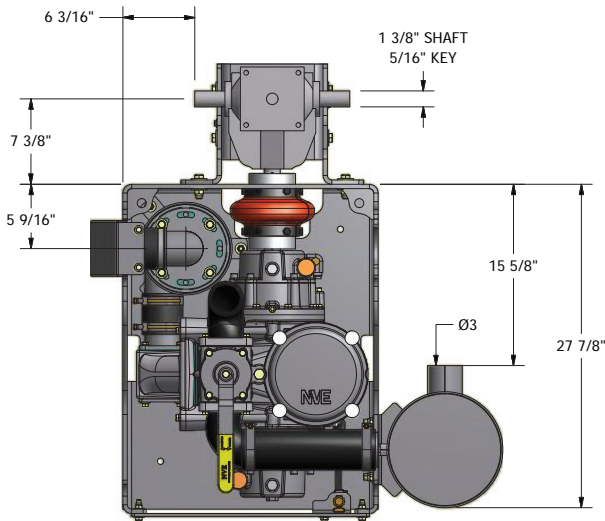

PRODUCT DESCRIPTION	PART NUMBER	WEIGHT
B500 Frame Mount Gearbox Drive RH Exhaust Silencer PKG (Pictured Above)	147-B500-002	702 lbs
B500 Frame Mount Hyd Adapter RH Exhaust Silencer PKG	147-B500-005	664 lbs
B500 Frame Mount Gearbox Drive LH Exhaust Silencer PKG	147-B500-007	702 lbs
B500 Frame Mount Hyd Adapter LH Exhaust Silencer PKG	147-B500-008	653 lbs

B500 Max Pak



MADE IN THE USA

Features

- B500 high vacuum tri-lobe blower with 4-way vacuum pressure change over valve
- Oil-less operation
- Aluminum Moisture Trap
- Exhaust air silencer
- Ballast air silencer
- 1:2 speed increasing right angle gearbox
- Clockable gearbox bracket for easy matching of drive line angles
- Pressure relief valves and vacuum pressure gauge
- Flows up to 431 CFM
- Designed, built, and supported in the USA

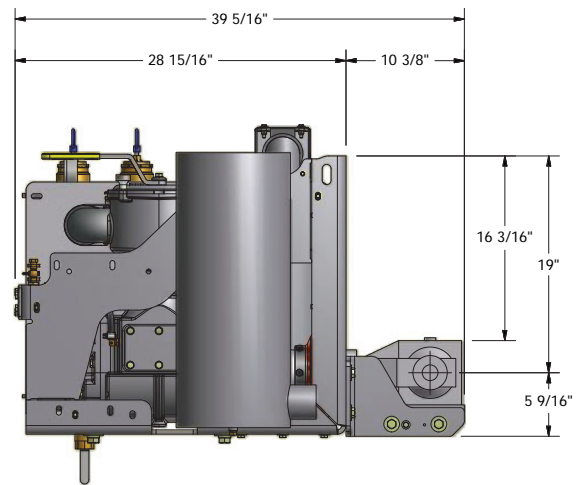
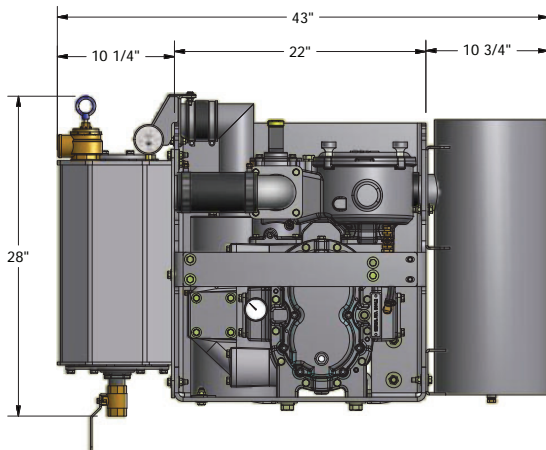
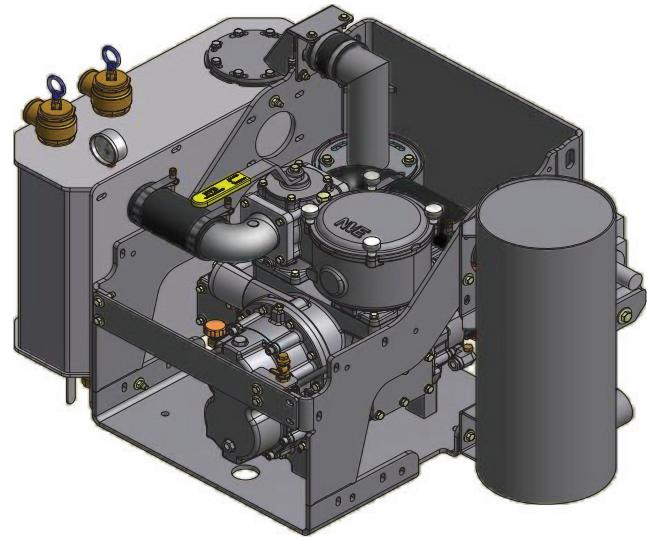
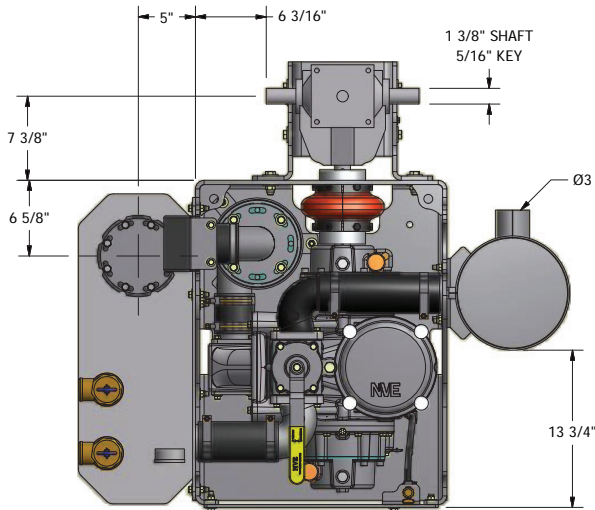

PRODUCT DESCRIPTION	PART NUMBER	WEIGHT
B500 Frame Mount Gearbox Drive RH MT & Exhaust Silencer Package	147-B500-001	774 lbs
B500 Frame Mount Gearbox Drive LH MT & Exhaust Silencer Package (Pictured Above)	147-B500-003	780 lbs
B500 Frame Mount Hyd Adapter RH MT & Exhaust Silencer Package	147-B500-004	736 lbs
B500 Frame Mount Hyd Adapter LH MT & Exhaust Silencer Package	147-B500-006	742 lbs

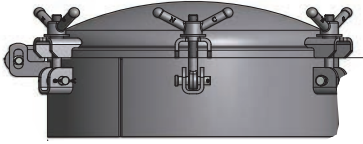

PRODUCT DESCRIPTION	PART NUMBER	WEIGHT
Portal Carbon 12" X 6" GOL	200-1206-C	37 lbs
Portal 12" X 6", Alu Base SS Lid GOL	204-1206-A	21 lbs
Manway Carbon 17" X 6" GOL	202-1706-C	48 lbs
Manway Carbon 20" X 6" GOL	202-2006	72 lbs
Manway Alu 20" X 6" W/ Cast Al Lid GOL	206-2006-A	42 lbs

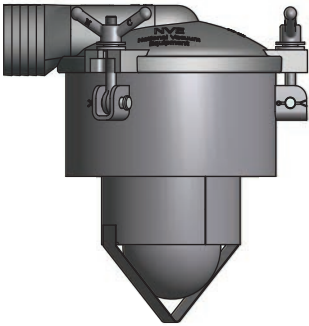

PRODUCT DESCRIPTION	PART NUMBER	WEIGHT
PSO 12" X 6" Carbon Base, Alu Lid 3" HB	200-1206-3HB	47 lbs
PSO 12" X 6" Alu Base, Alu Lid 3" HB	204-1206-3HB	32 lbs
PSO 12" X 6" Ss Base Alu Lid 3" HB	208-1206-3HB	45 lbs

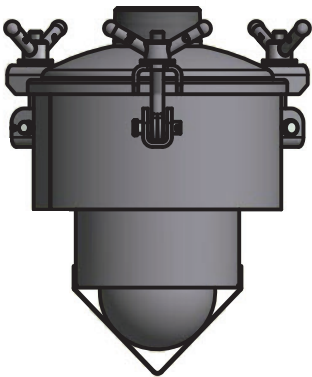

DESCRIPTION	PART NUMBER	WEIGHT
PSO 12" X 6" Carbon Base, Carbon Lid 3" NPT	200-1206-3NPT	45 lbs
PSO 12" X 12" Carbon Base, Carbon Lid 3" NPT	200-1212-3NPT	61 lbs
PSO 12" X 6" Ss Base, Stainless Steel Lid 3" NPT	208-1206-3NPT	45 lbs

B500 Components & Accessories



MADE IN THE USA



DESCRIPTION	PART NUMBER	WEIGHT
MT 10 Gal Alu 3" NPT SS Lid	216-100-3NPT-AS	48 lbs
MT 10 Gal SS 3" NPT	216-100-3NPT-S	60 lbs
MT 10 Gal Carbon 3" NPT	216-100-3NPT-C	91 lbs



PRODUCT DESCRIPTION	PART NUMBER	WEIGHT
Aluminum Trap Right Hand	218-001-B500-R	72 lbs
Aluminum Trap Left Hand	218-001-B500-L	72 lbs

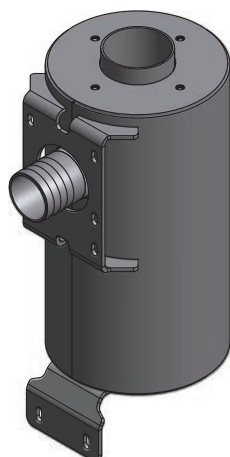

PRODUCT DESCRIPTION	PART NUMBER	WEIGHT
Exhaust Silencer B500	224-360-008	69 lbs

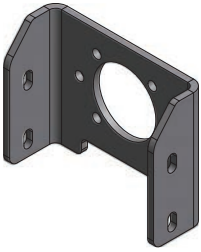

PRODUCT DESCRIPTION	PART NUMBER	WEIGHT
Hydraulic Adapter Kit	280-355-227	- - - - -
Gearbox Bracket Kit	280-401-008	23.8 lbs

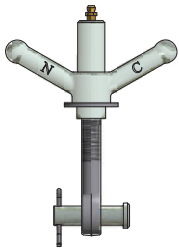

PRODUCT DESCRIPTION	PART NUMBER	WEIGHT
Wingnut, Eyebolt Clevis & Cotter Pin (Qty 6)	284-KIT-C	1.45 lbs
Lubenut, Eyebolt, Clevis & Cotter Pin (Qty 6)	284-KIT-CLN	1.55 lbs



PRODUCT DESCRIPTION	PART NUMBER	WEIGHT
Float Ball 6" SS	414-600-SS	1.1 lbs



PRODUCT DESCRIPTION	PART NUMBER	WEIGHT
Gasket 12" Lid And Neck Buna	286-706-12L	0.65 lbs
Gasket 19.5" Lid Buna	286-706-20L	1 lbs

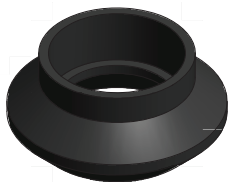

PRODUCT DESCRIPTION	PART NUMBER	WEIGHT
Ball Seat 3" Buna	416-300-B	0.55 lbs
Clamp Worm 3" Ball Seats	416-300-1WC	0.08 lbs
Ball Seat 4" Buna	416-400-B	1.10 lbs
Clamp Worm 4" Ball Seat	416-400-1WC	.09 lbs

B500 Components & Accessories



MADE IN THE USA

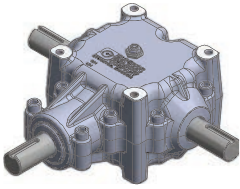

PRODUCT DESCRIPTION	PART NUMBER	WEIGHT
Gearbox 500 series 1:2 with 1 3/8" shaft	422-500-1	27.75 lbs



PRODUCT DESCRIPTION	QTY	PART NUMBER	WEIGHT
Coupler Hub E20 1 3/8" Bore 5/16" key	2	424-200-1375	7.25 lbs
Coupler Flex Element E20		424-200-E20	4.15 lbs



PRODUCT DESCRIPTION	PART NUMBER	WEIGHT
Elbow 3" 90 Degree Alum Hose Barb X Hose Barb	803-063-011	0.69 lbs

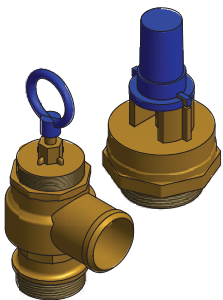

PRODUCT DESCRIPTION	PART NUMBER	WEIGHT
Vacuum Relief 1 1/2" NPT	366-150	1.1 lbs
Pressure Relief 1 1/2"	364-306-015	1.85 lbs
Pressure Relief 1 1/4"	364-306-1.25	1.45 lbs
Pressure Relief 2"	364-306-2	2.7 lbs

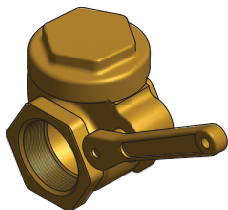

PRODUCT DESCRIPTION	PART NUMBER	WEIGHT
Lever Valve 2"	362-301-2	3.9 lbs
Lever Valve 3"	362-301-3	8.7 lbs
Lever Valve 4"	362-301-4	12 lbs

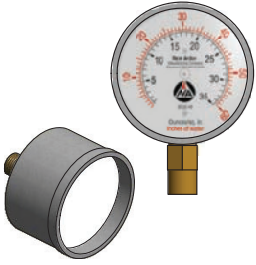

PRODUCT DESCRIPTION	PART NUMBER	WEIGHT
Gauge 2.5" Vac/Press Liq Back Conn 1/4" NPT	408-200-009	.45 lbs
Gauge 2.5" Vac/Pres Liq Bot Conn 1/4" NPT	408-250-LF	.45 lbs



PRODUCT DESCRIPTION	PART NUMBER	WEIGHT
Flush Fluid Kit	320-081-002	2 lbs



PRODUCT DESCRIPTION	PART NUMBER	WEIGHT
Intake Filter Element B500	120-314-006z	.80 lbs

NVE

National Vacuum Equipment

■ Part of Atlas Copco Group

Revised 04/2025



**DESIGNED.
BUILT.
SUPPORTED.**

Produced in the USA | Distributed World-Wide

Challenger Series
VACUUM PUMPS & BLOWERS

800-253-5500

sales@natvac.com

2707 Aero Park Dr. | Traverse City, MI 49686

